

Set [g/h/i] Spacer, [f] Flange, Grinding Cup, then tighten [e] Lock-Nut with Wrench.

※In the case of h21mm Grinding Cup.

4

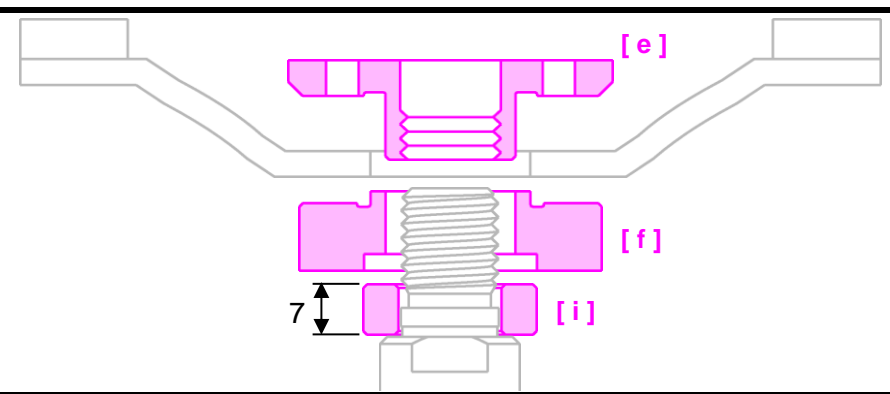

Hold the Inner Plate of [a] and tighten the Bolt with [d] Wrench securely.

Inner Plate

Bolt

3

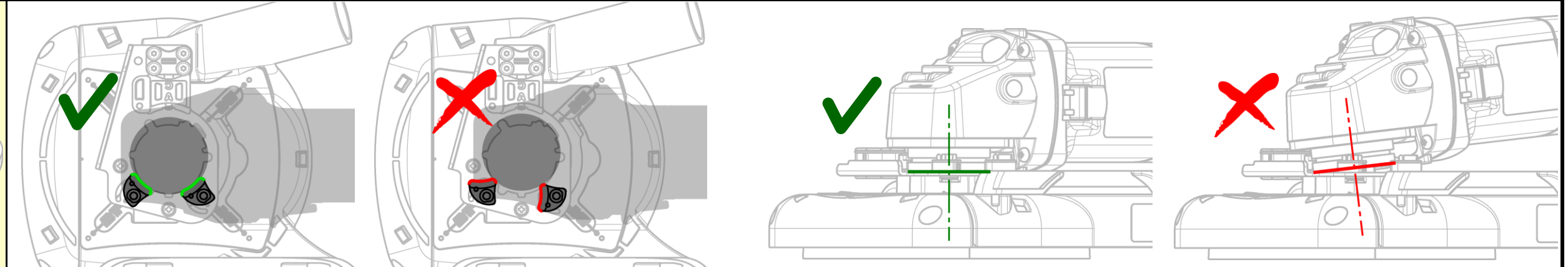

Place [a] on the gearcase of the Grinder.

[b] Some models ONLY.

2

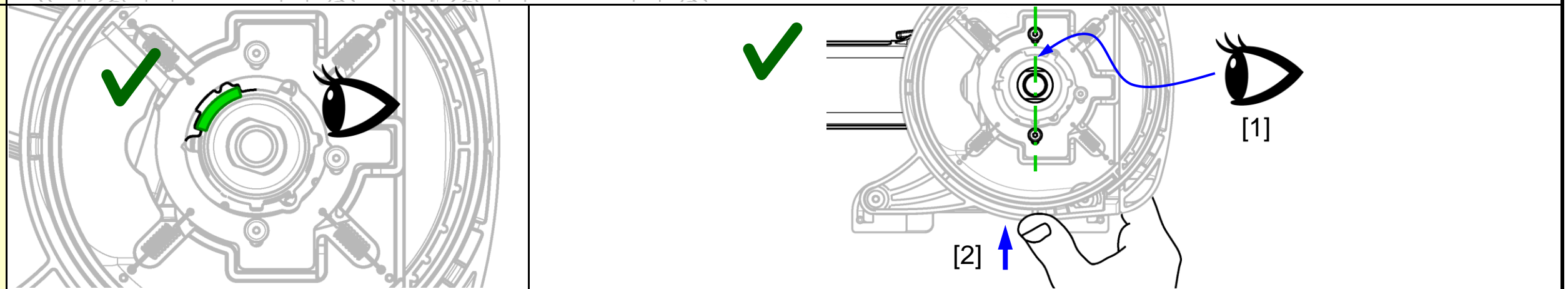

Set Upper / Lower Brackets at [a] Main Unit.

Upper Bracket

Lower Brackets

[a]

1

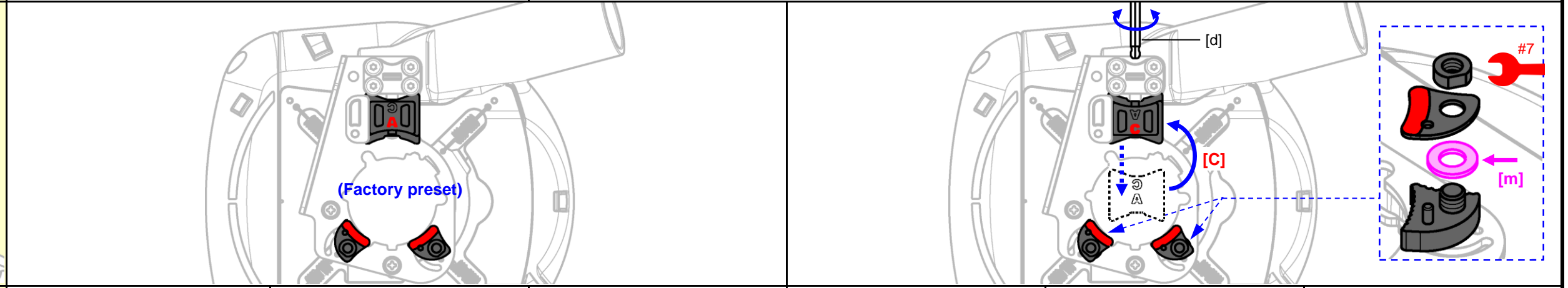

**Makita**

⚠ XLOCK model can't be fitted.

※Based on the web information as of 2022 Jan.

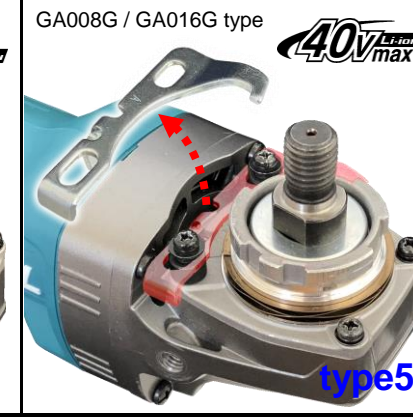
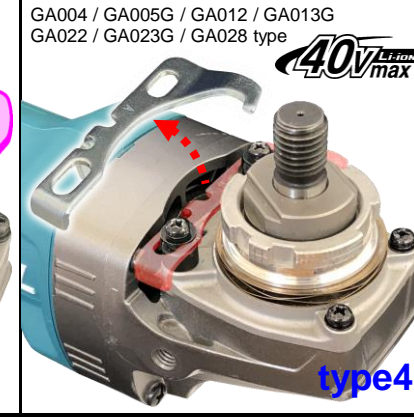
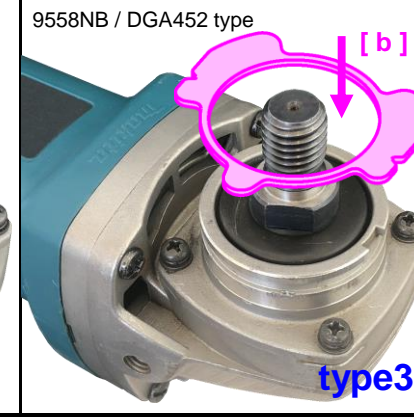
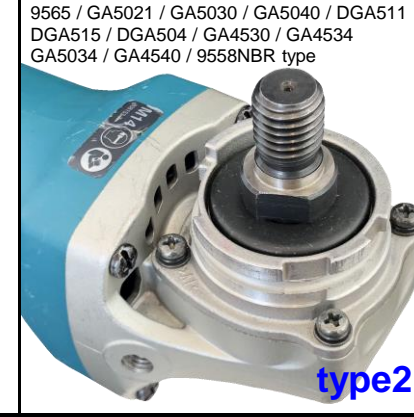
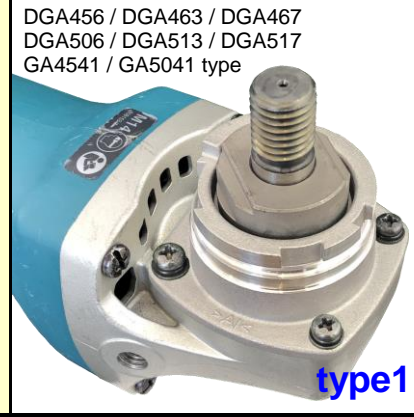



Set [g/h/i] Spacer, [f] Flange, Grinding Cup, then tighten [e] Lock-Nut with Wrench.

※In the case of h21mm Grinding Cup.

4

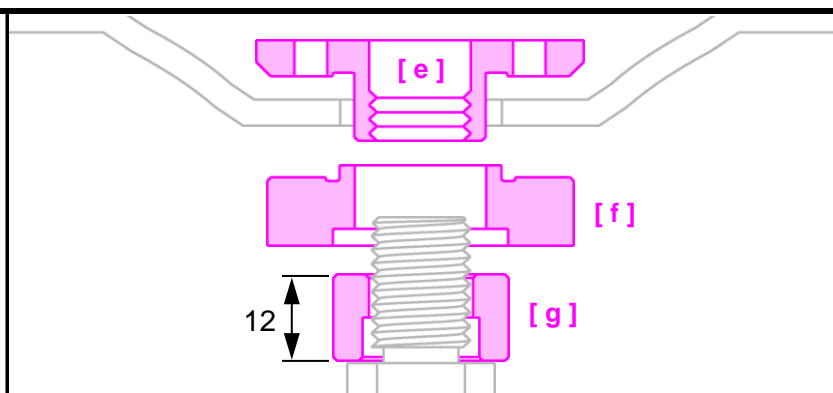
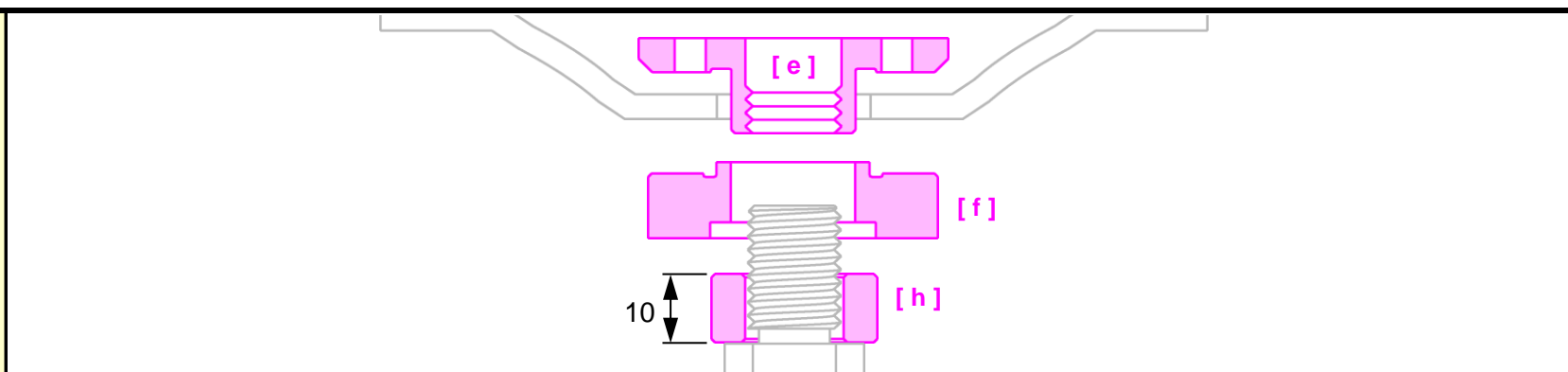

Hold the Inner Plate of [a] and tighten the Bolt with [d] Wrench securely.

Inner Plate

Bolt

3

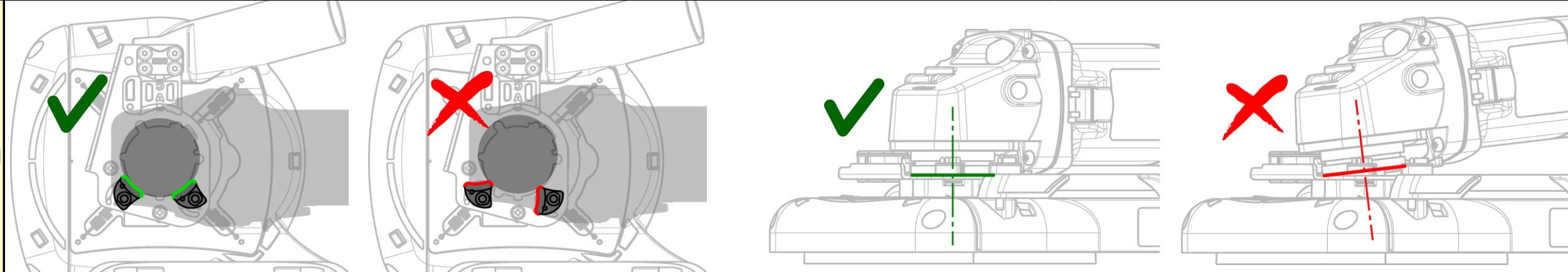

Place [a] on the gearcase of the Grinder.

2

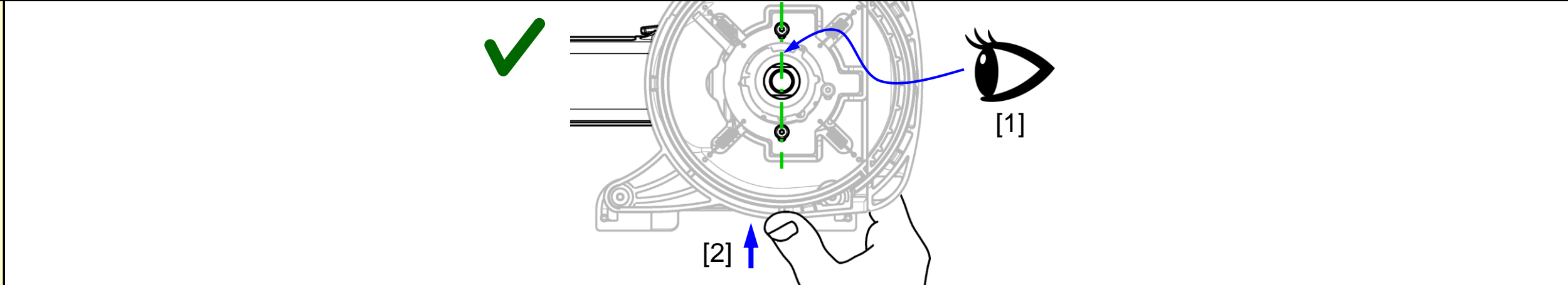

Set Upper / Lower Brackets at [a] Main Unit.

Upper Bracket

Lower Brackets

[a]

1

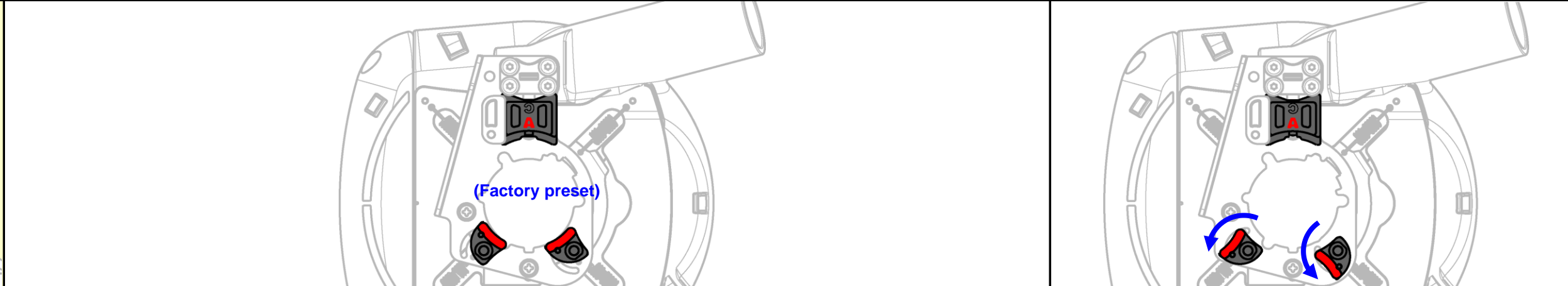

**BOSCH**

⚠ XLOCK model can't be fitted.

※Based on the web information as of 2022 Jan.

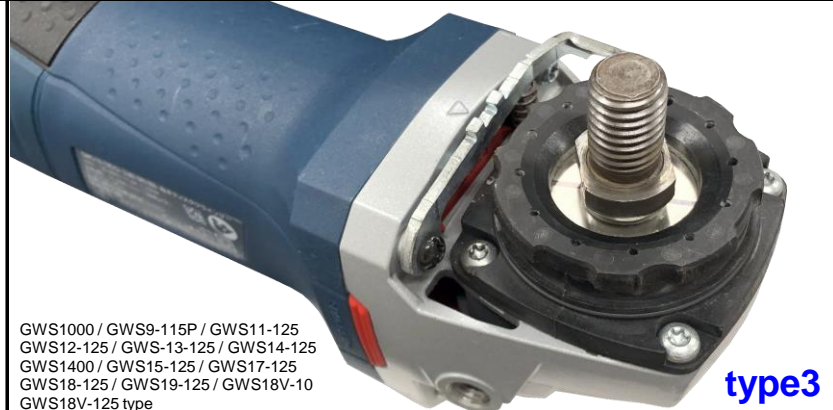
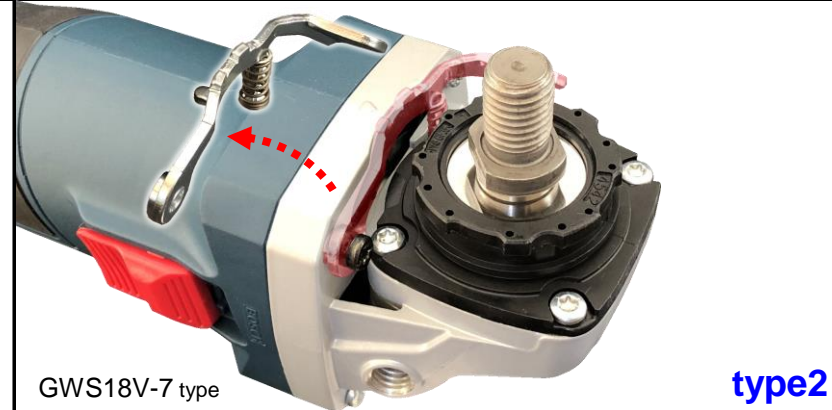



Set [g/h/i] Spacer, [f] Flange, Grinding Cup, then tighten [e] Lock-Nut with Wrench.

※In the case of h21mm Grinding Cup.

4

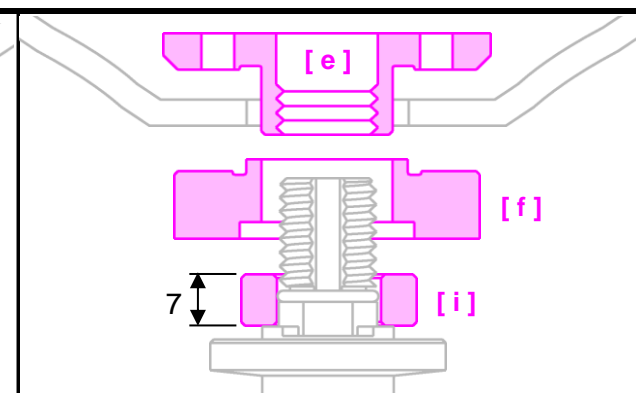
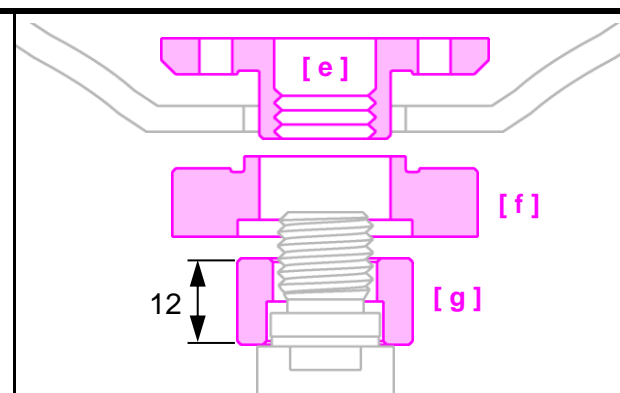
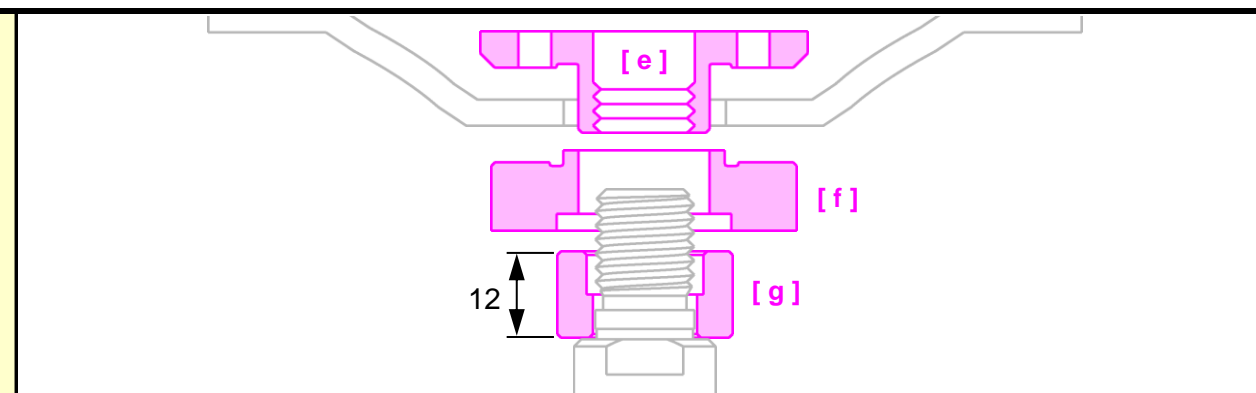

Hold the Inner Plate of [a] and tighten the Bolt with [d] Wrench securely.

Inner Plate

Bolt

3

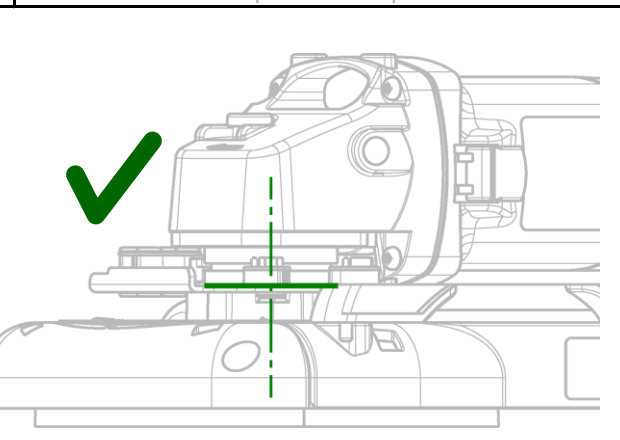
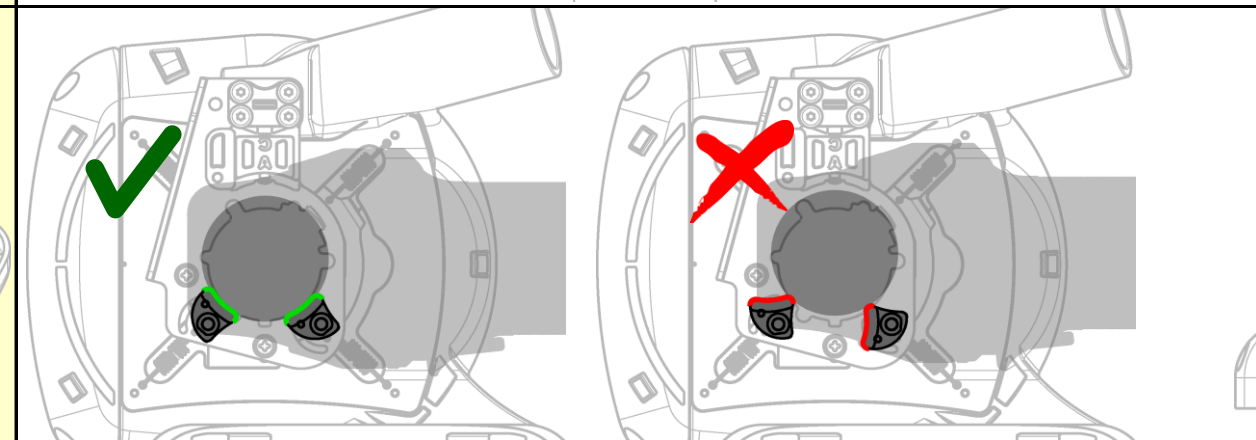

Place [a] on the gearcase of the Grinder.

Some models ONLY. [b]

2

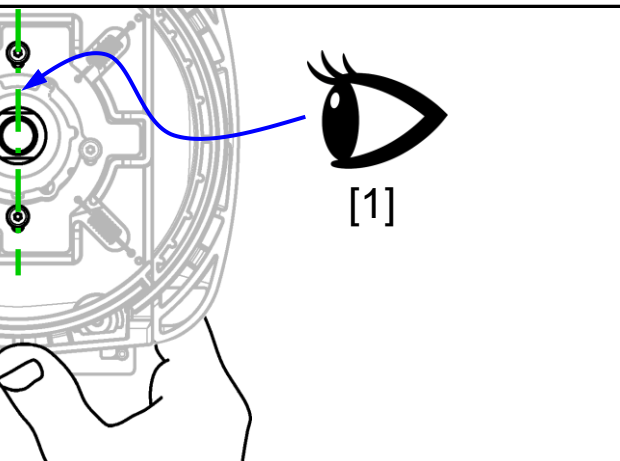

Set Upper / Lower Brackets at [a] Main Unit.

Upper Bracket

Lower Brackets

[a]

1

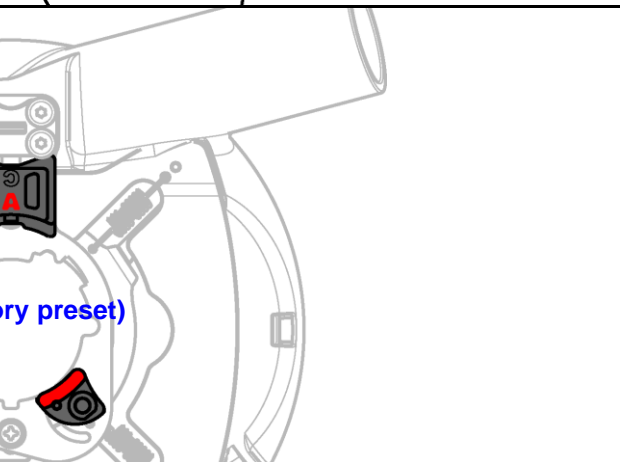

⚠ D28137 / DCG405FN can't be fitted.

※Based on the web information as of 2022 Jan.

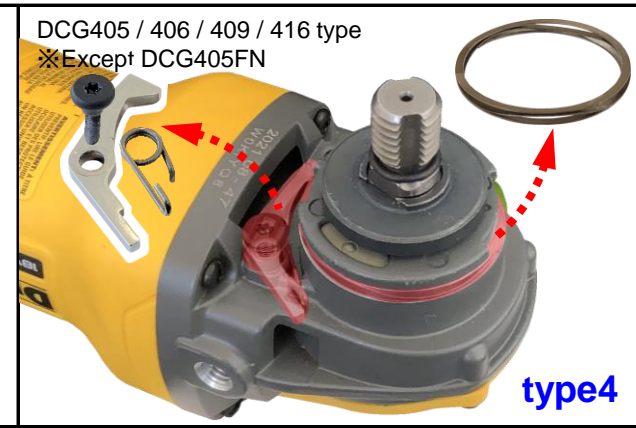
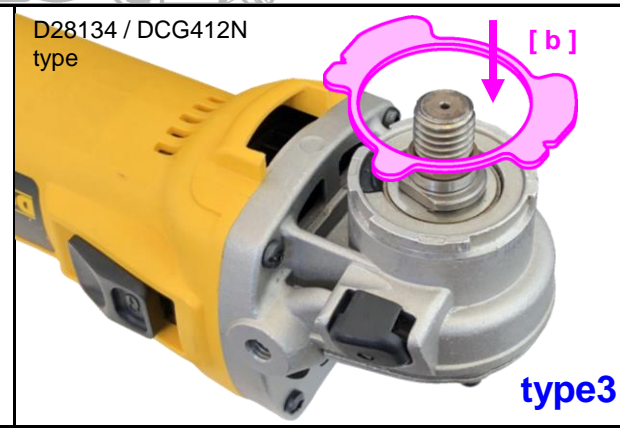
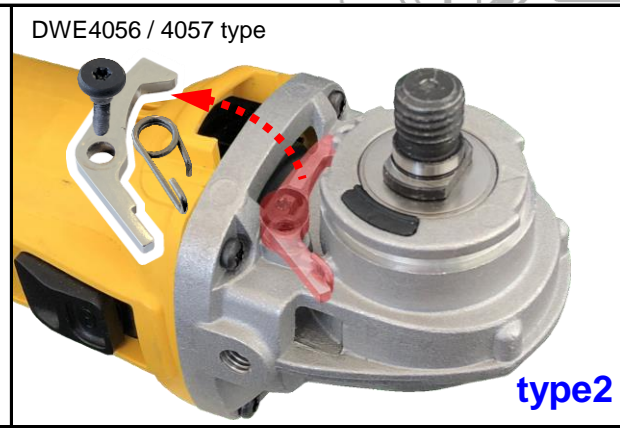
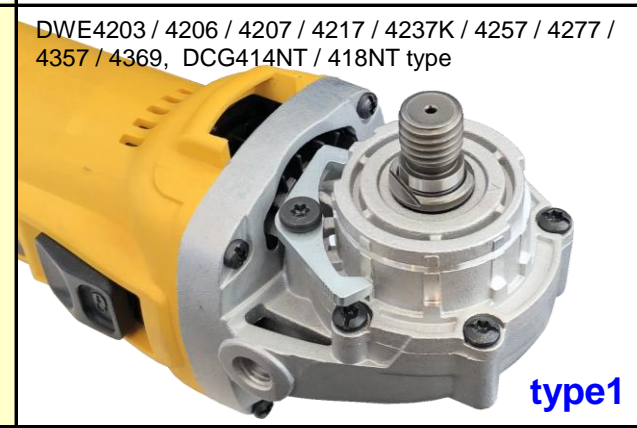



Set [g/h/i] Spacer, [f] Flange, Grinding Cup, then tighten [e] Lock-Nut with Wrench.

※In the case of h21mm Grinding Cup.

4

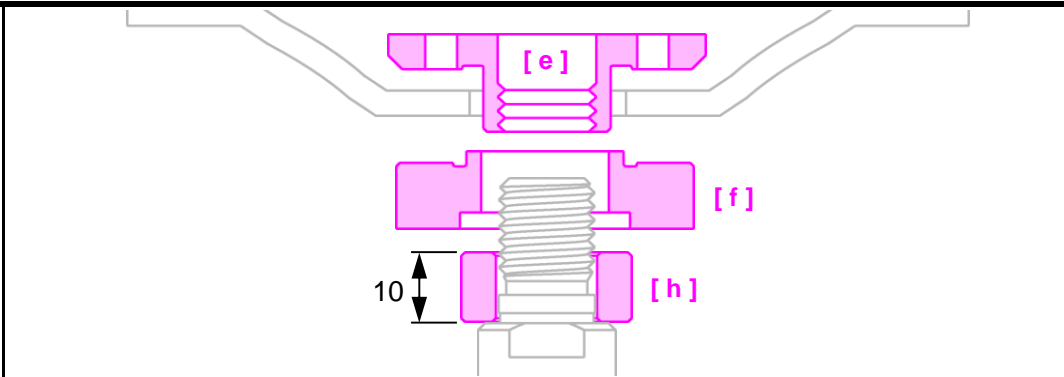
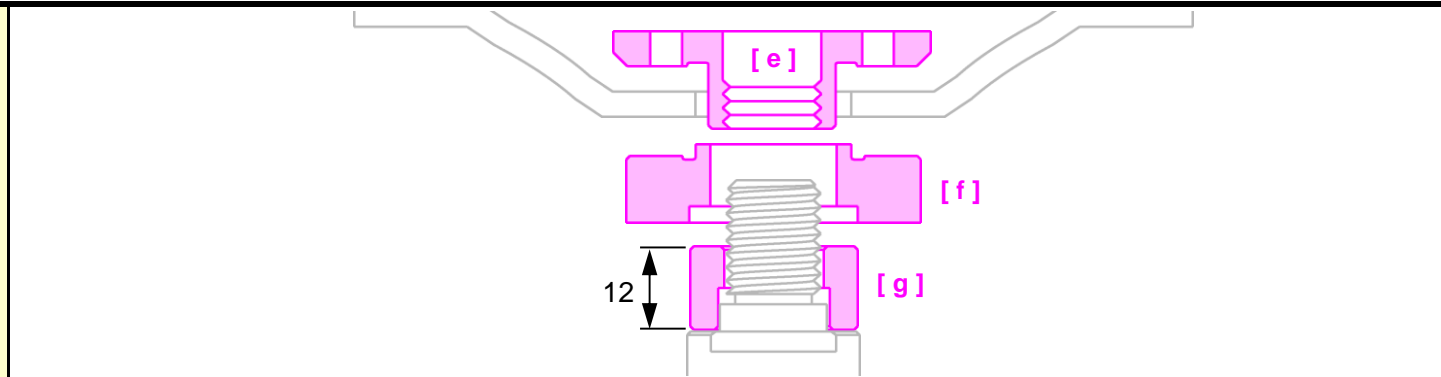

Hold the Inner Plate of [a] and tighten the Bolt with [d] Wrench securely.

Inner Plate [a]

Bolt

3

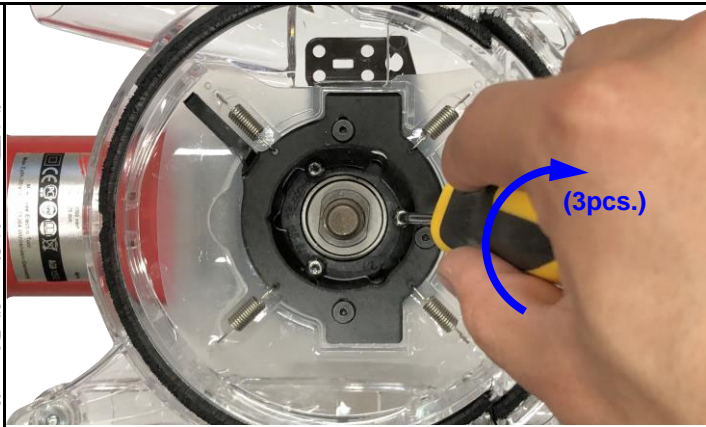
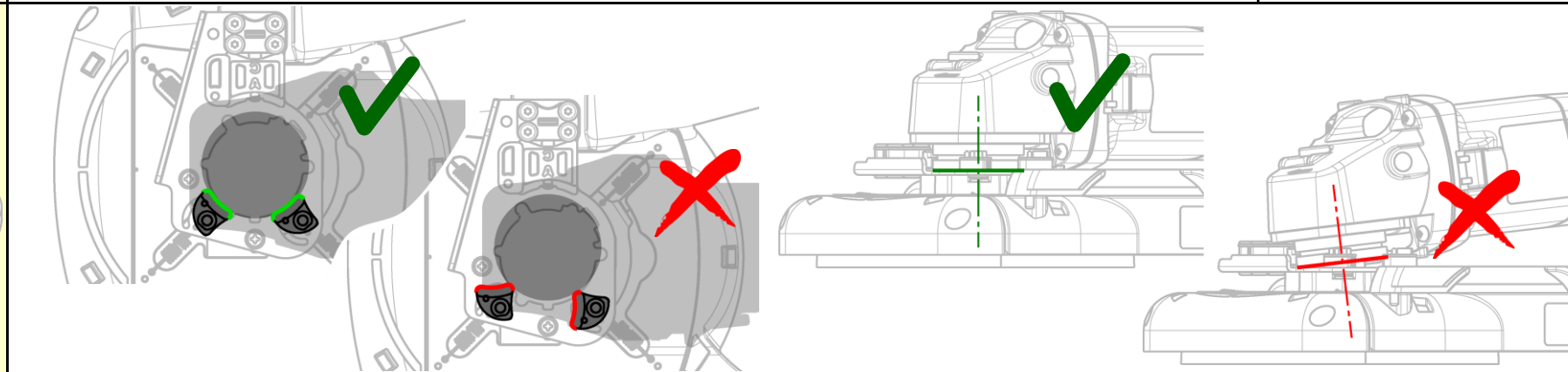

Place [a] on the gearcase of the Grinder.

[b/c] (Some models ONLY)

2

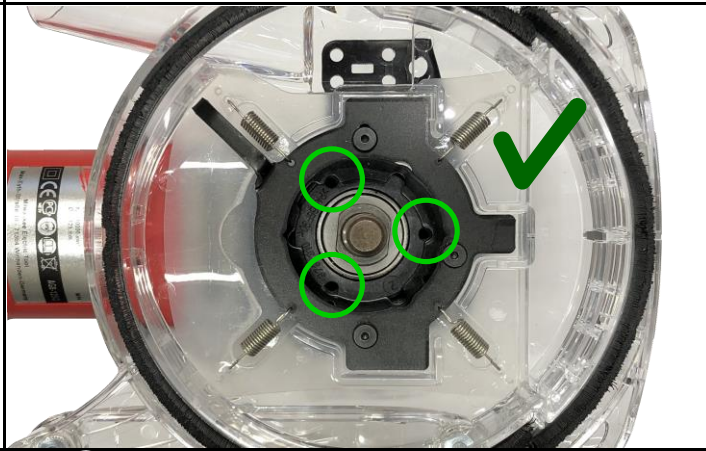
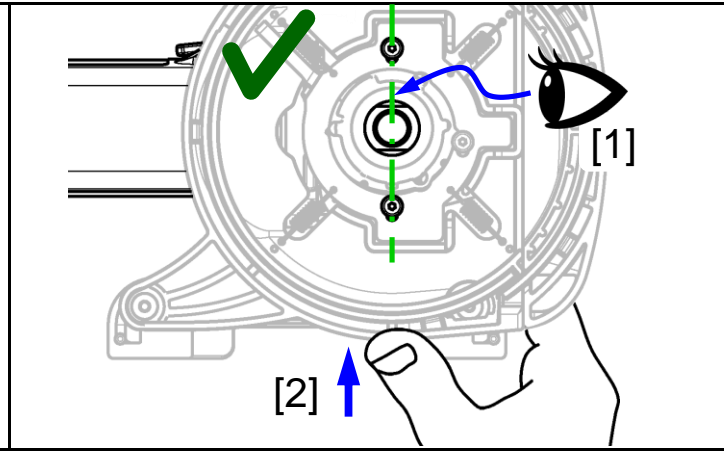
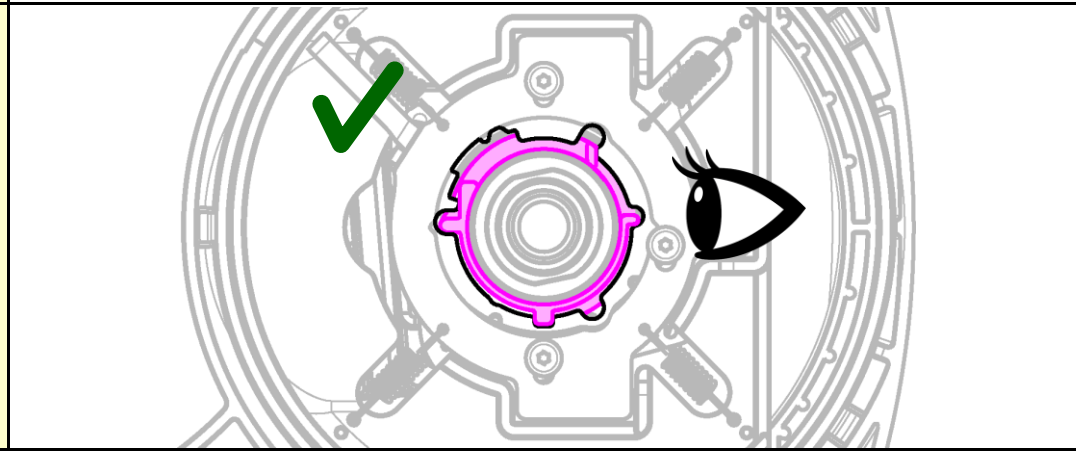

Set Upper / Lower Brackets at [a] Main Unit.

Upper Bracket

Lower Brackets

[a]

1

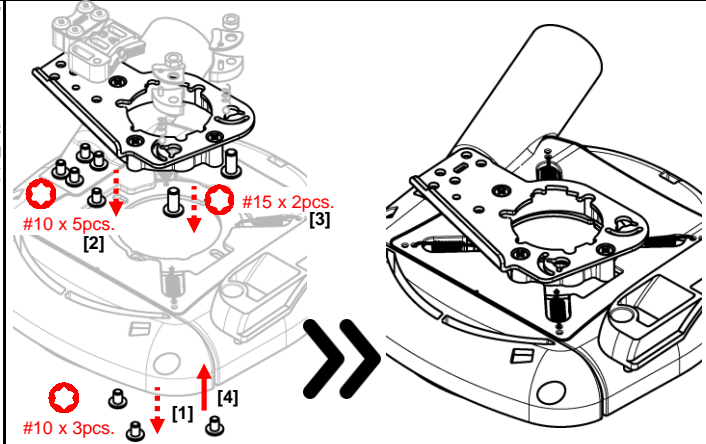
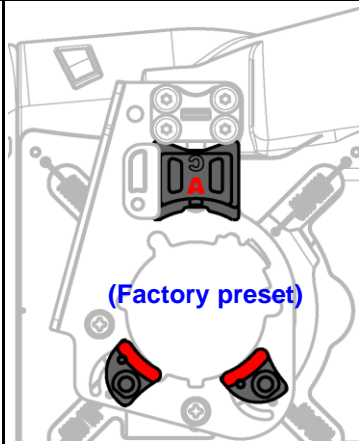
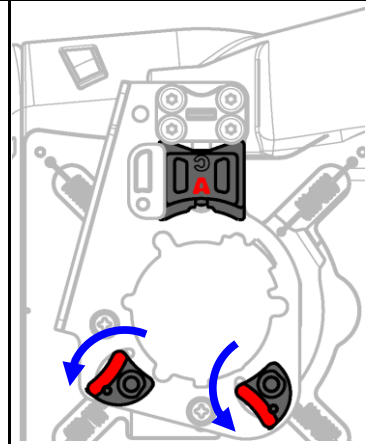
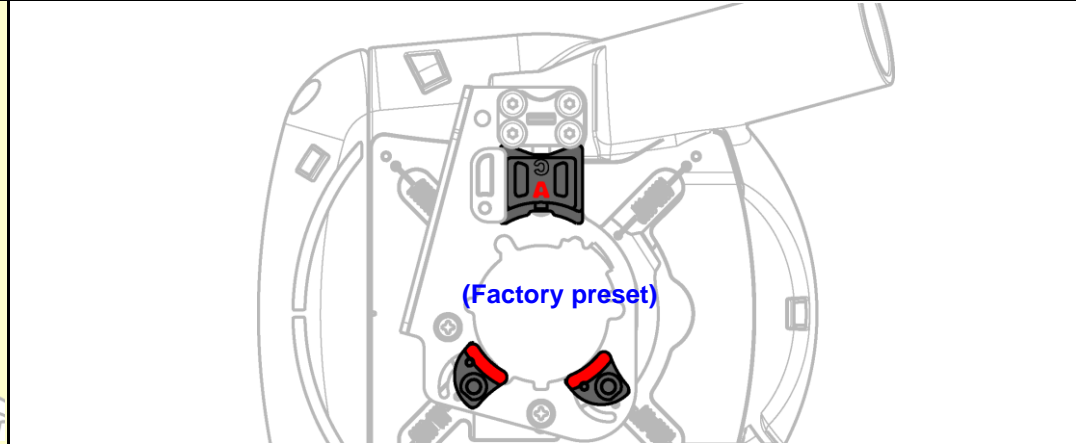

AGV10-125EK, AG10-125EK, AG800-125EK type can't be fitted.

※Based on the web information as of 2022 Jan.

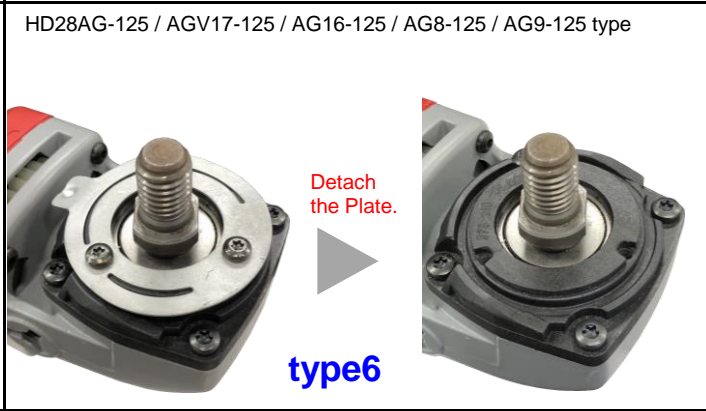
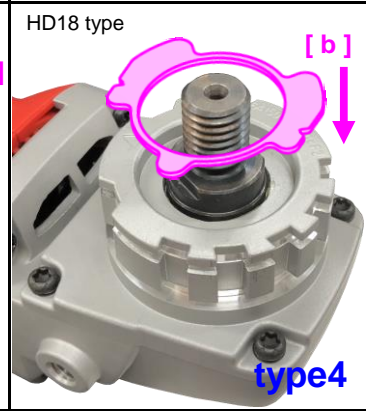
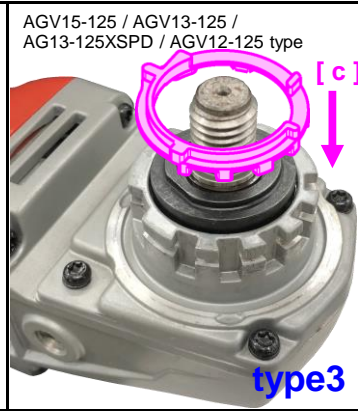
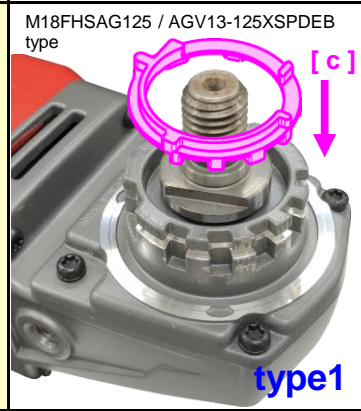



Set [g/h/i] Spacer, [f] Flange, Grinding Cup, then tighten [e] Lock-Nut with Wrench.

※In the case of h21mm Grinding Cup.

4

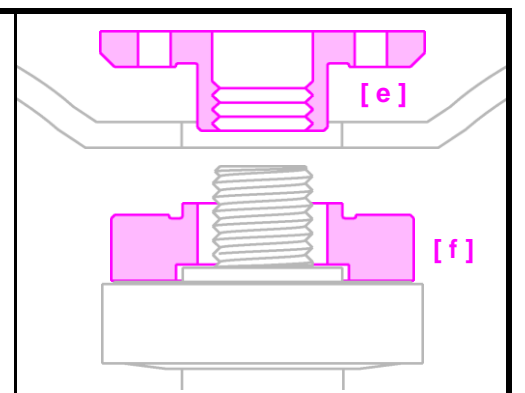
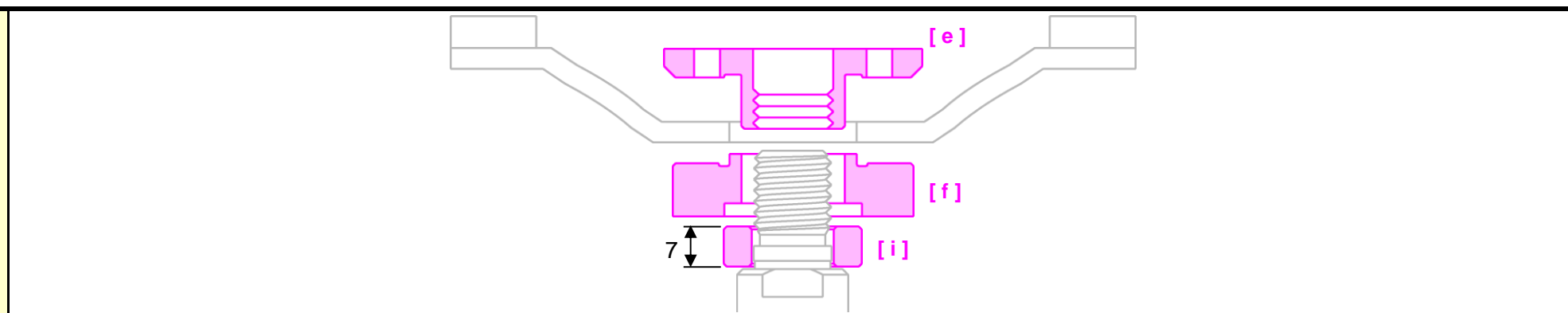

Hold the Inner Plate of [a] and tighten the Bolt with [d] Wrench securely.

Inner Plate

Bolt

[d]

3

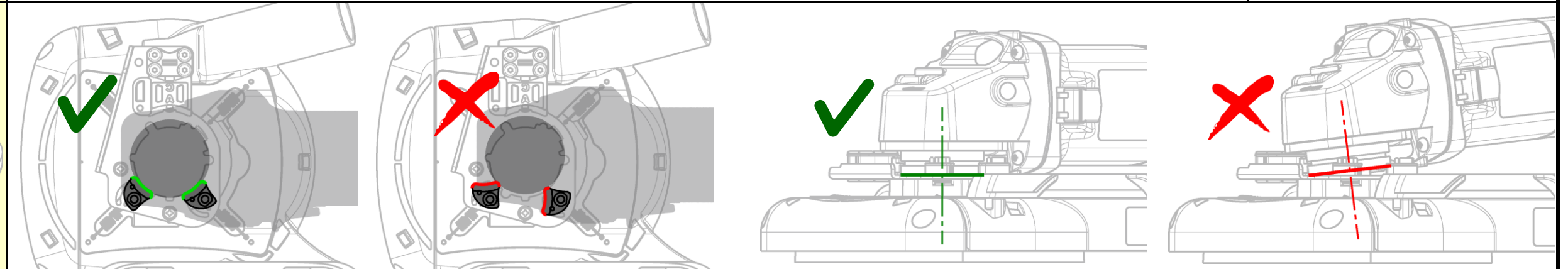

Place [a] on the gearcase of the Grinder.

2

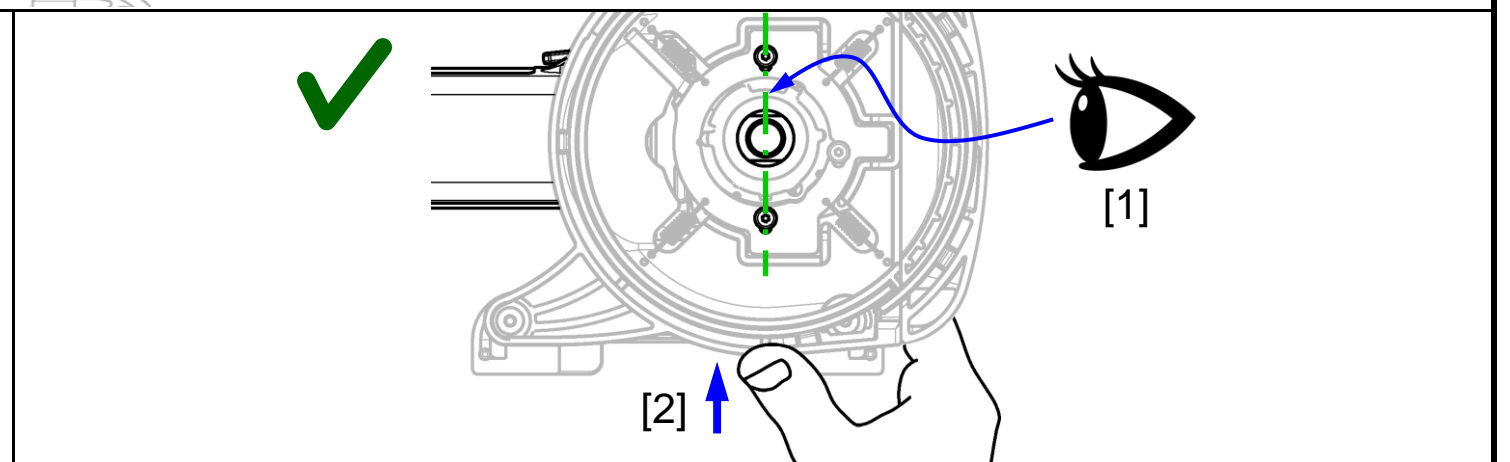
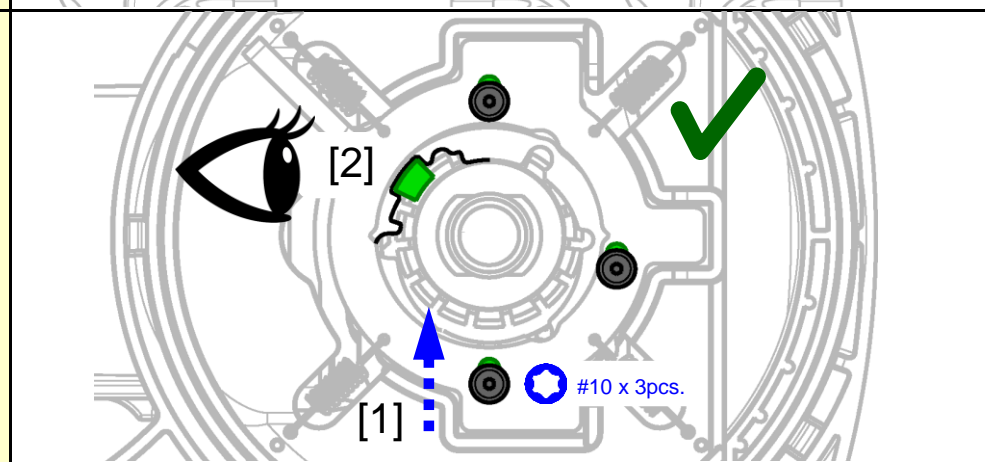

Set Upper / Lower Brackets at [a] Main Unit.

Upper Bracket

Lower Brackets

[a]

1

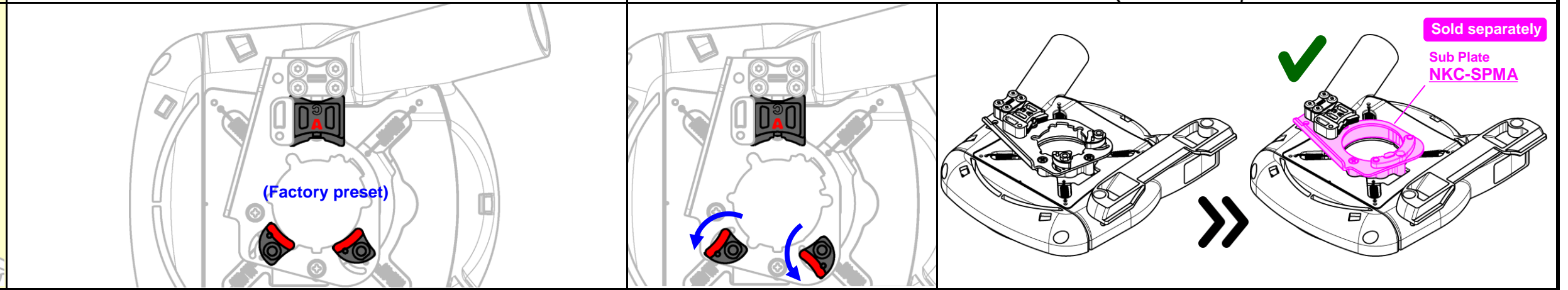

**metabo**

※Based on the web information as of 2022 Jan.

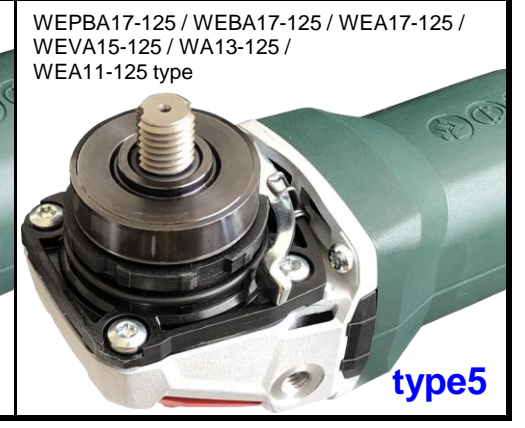
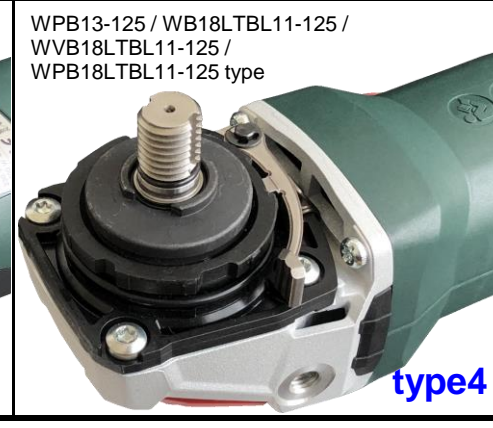
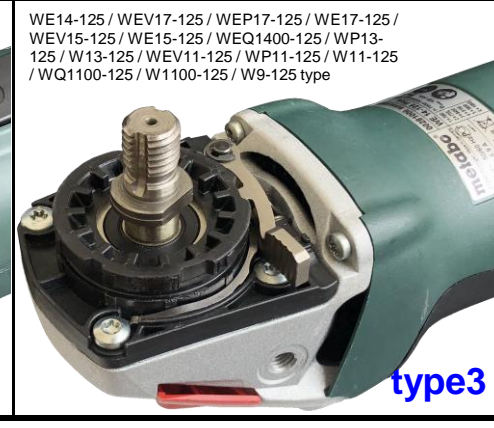
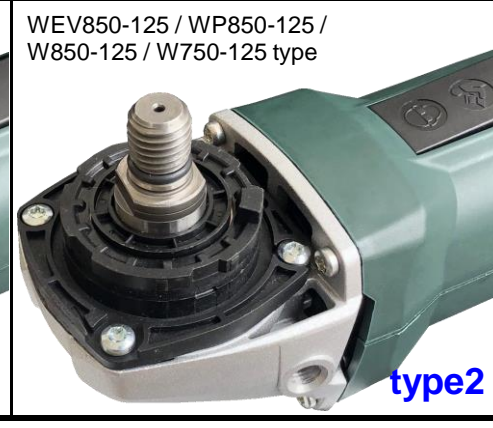
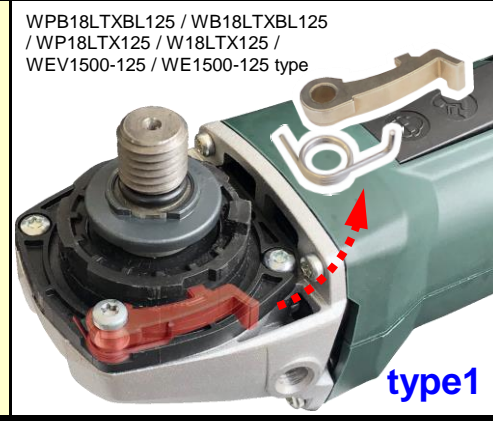



Set [g/h/i] Spacer, [f] Flange, Grinding Cup, then tighten [e] Lock-Nut with Wrench.

※In the case of h21mm Grinding Cup.

4

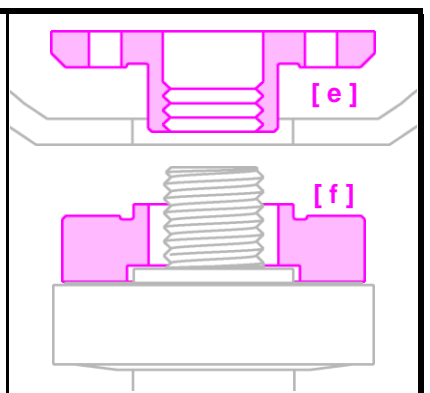
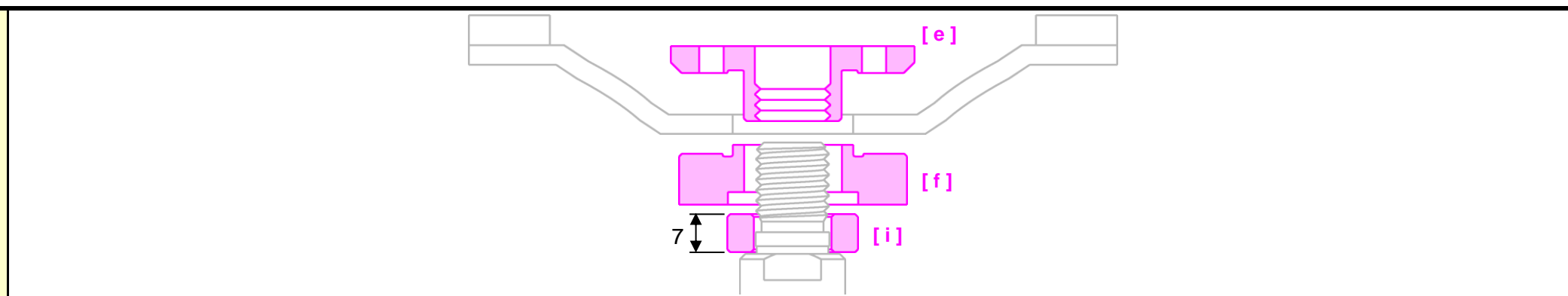

Hold the Inner Plate of [a] and tighten the Bolt with [d] Wrench securely.

Inner Plate

Bolt

3

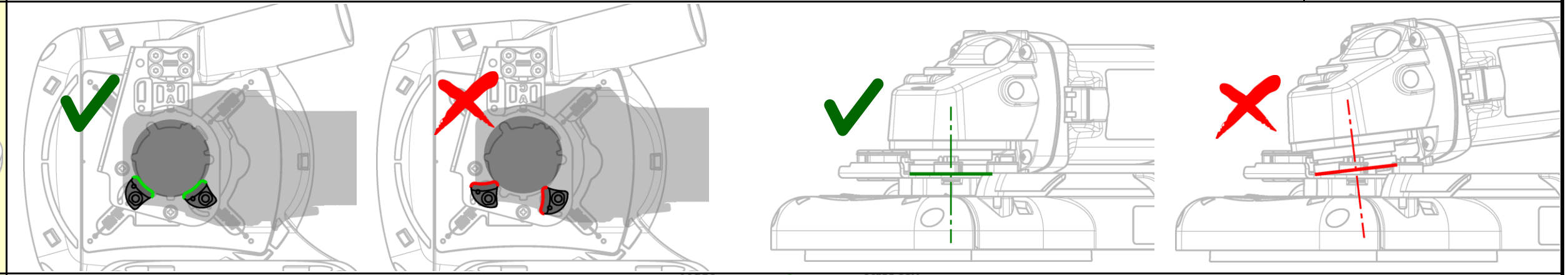

Place [a] on the gearcase of the Grinder.

2

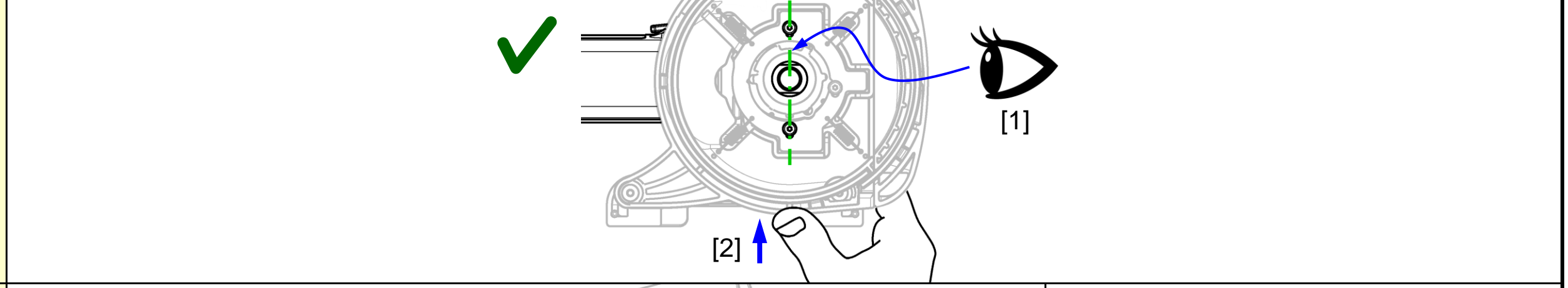

Set Upper / Lower Brackets at [a] Main Unit.

Upper Bracket

Lower Brackets

[a]

1

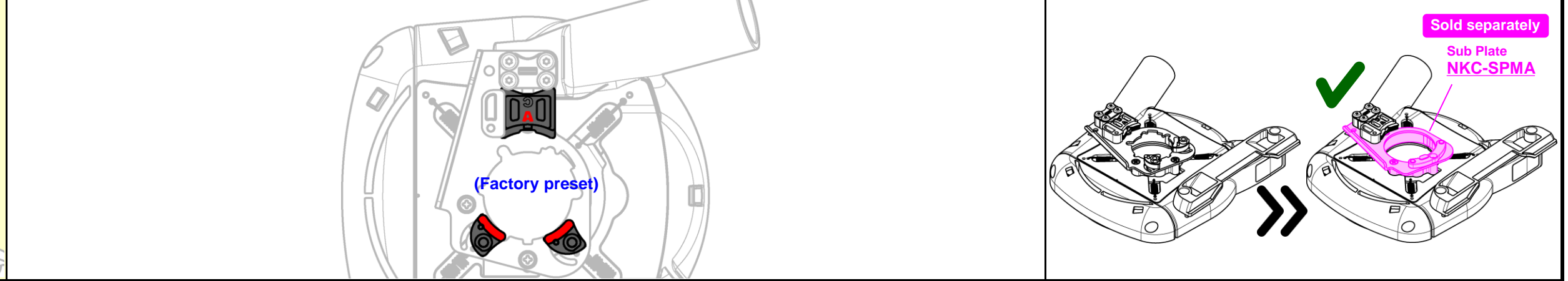

**HIKOKI**

※Based on the web information as of 2022 Jan.

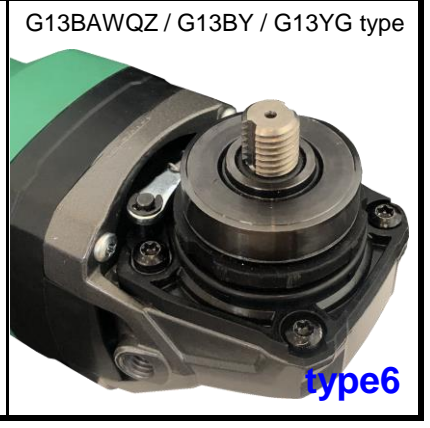
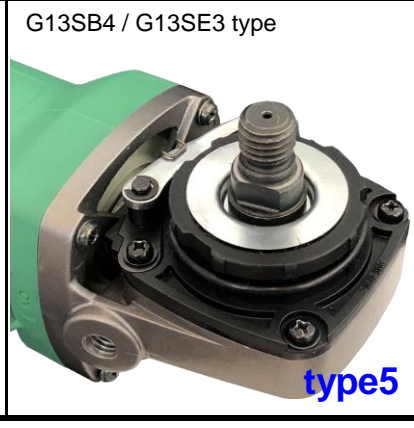
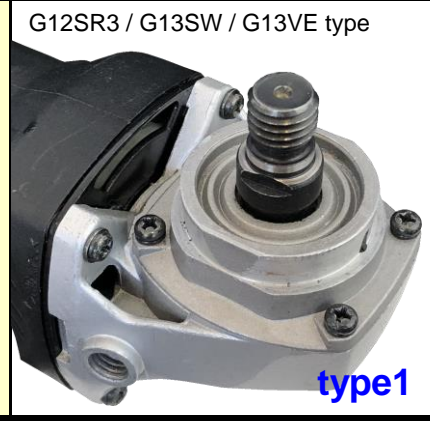



Set [g/h/i] Spacer, [f] Flange, Grinding Cup, then tighten [e] Lock-Nut with Wrench.

※In the case of h21mm Grinding Cup.

**4**

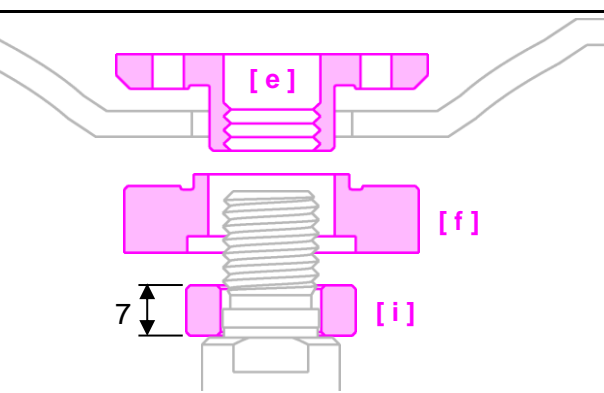
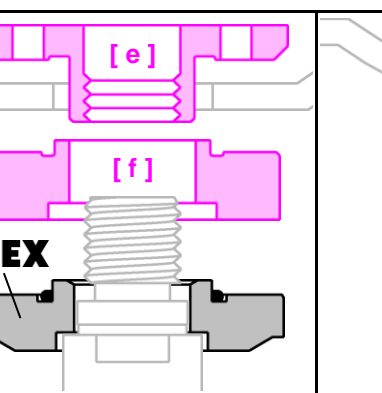
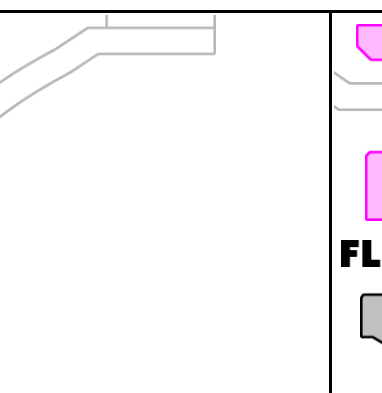
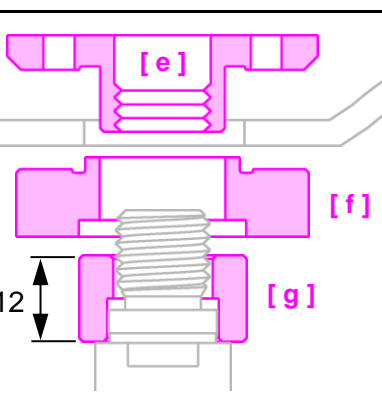
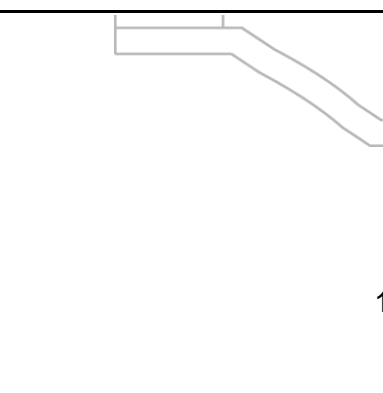
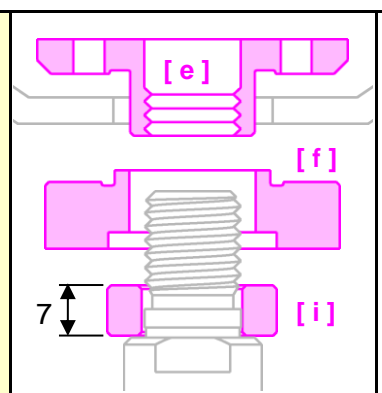

Hold the Inner Plate of [a] and tighten the Bolt with [d] Wrench securely.

Inner Plate [d]

Bolt

**3**

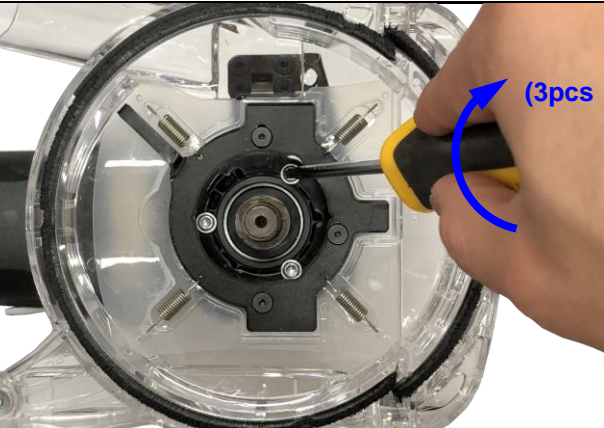
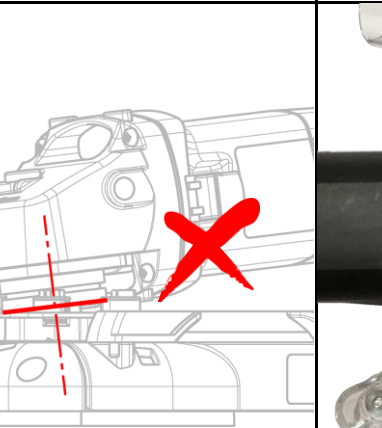
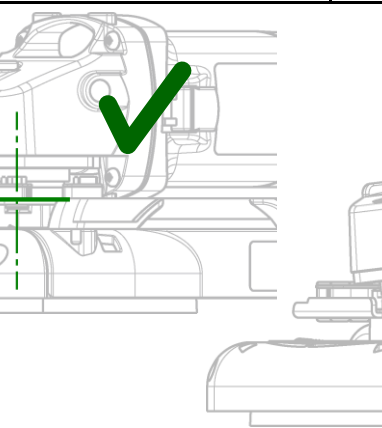
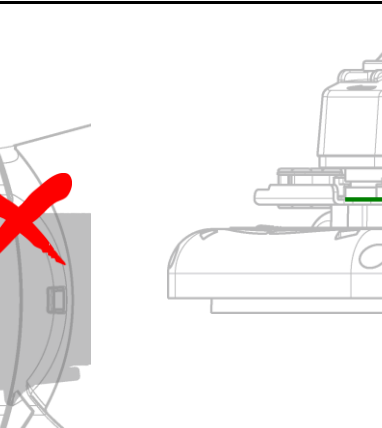
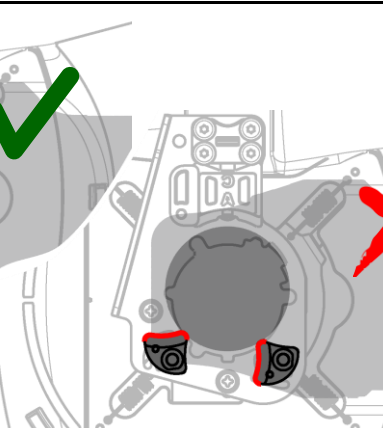
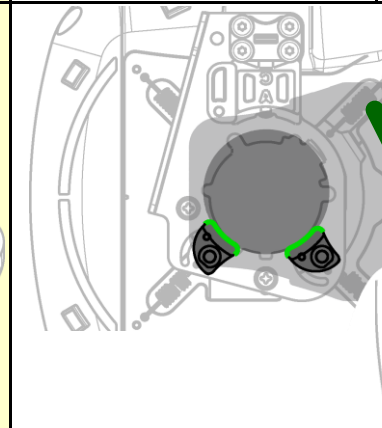

Place [a] on the gearcase of the Grinder.

[b] Some models ONLY.

**2**

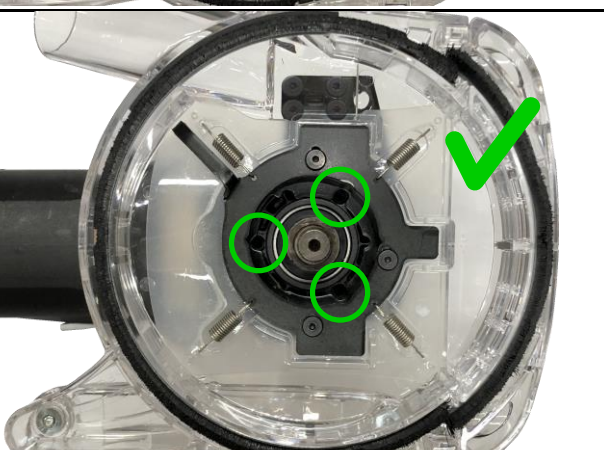
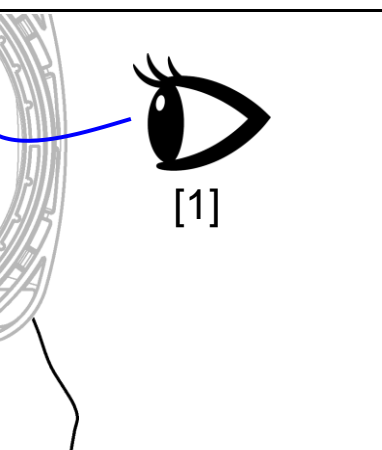
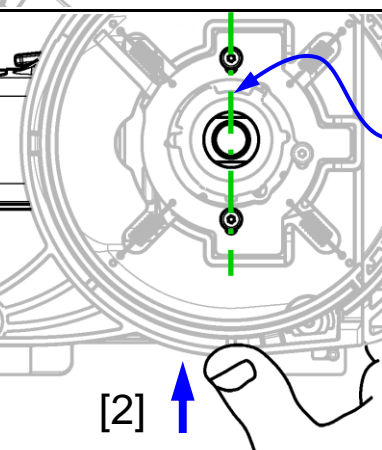
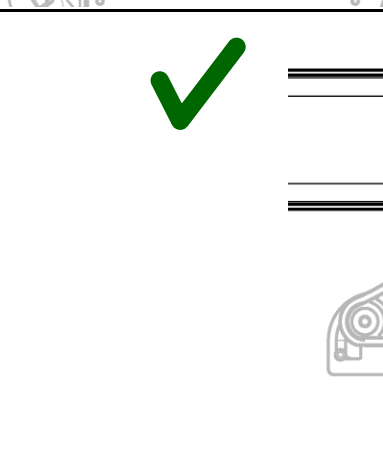

Set Upper / Lower Brackets at [a] Main Unit.

Upper Bracket [a]

Lower Brackets

**1**

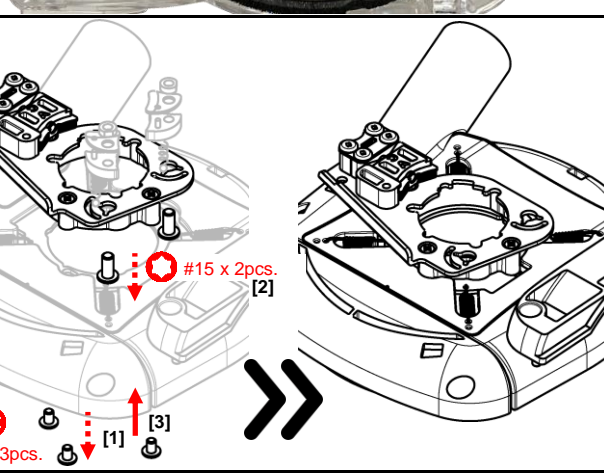
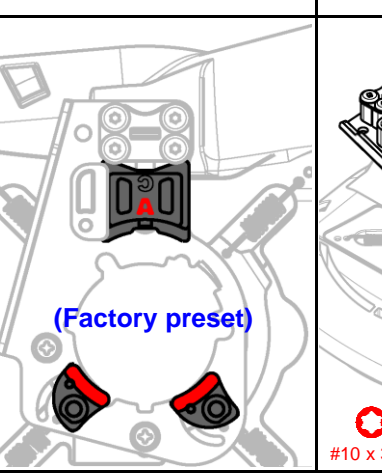
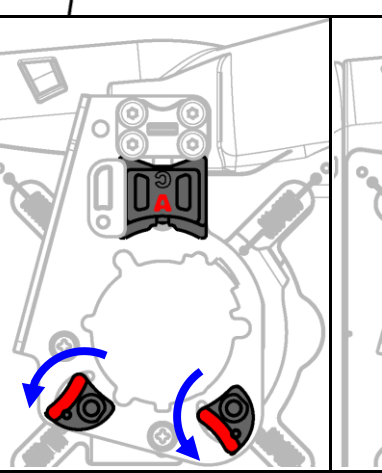
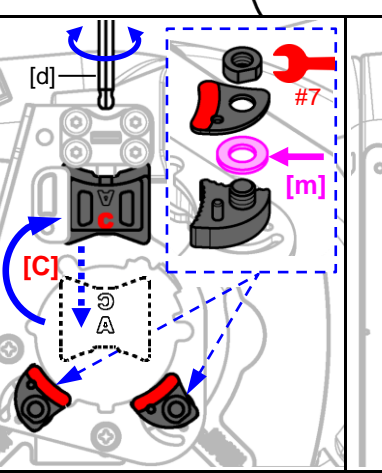
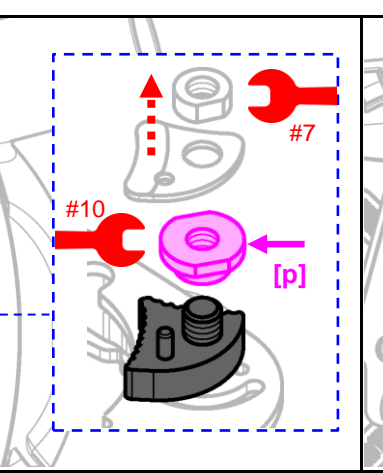
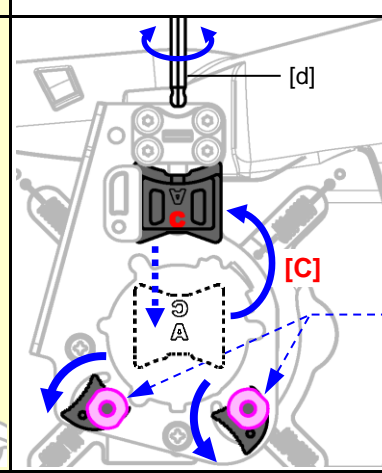

**FLEX**

※Based on the web information as of 2022 Jan.

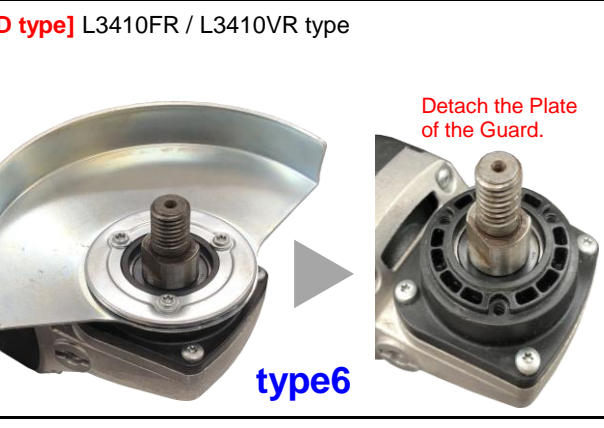
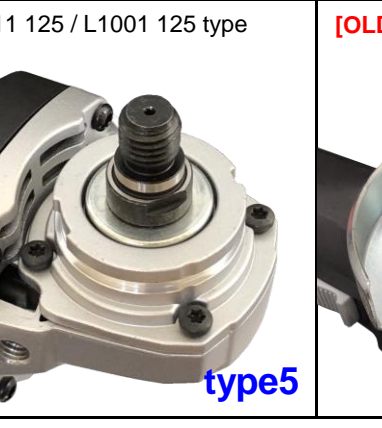
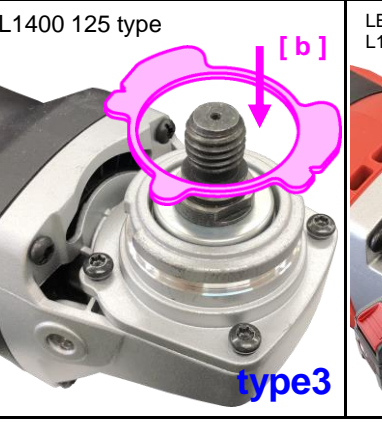
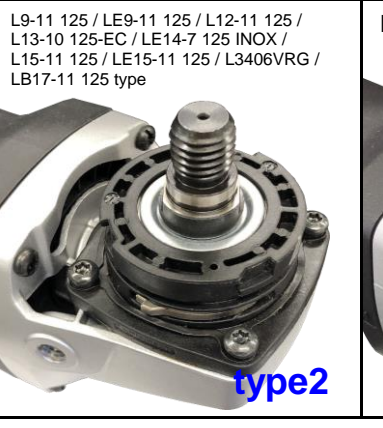



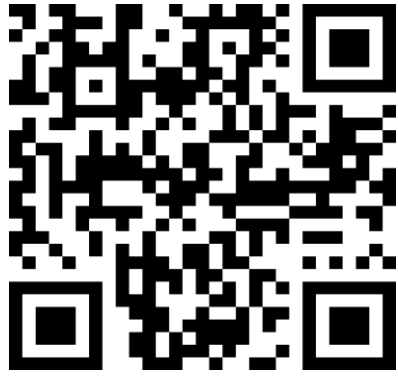

Check the  
instruction  
video.

