

⚠ WARNING

- DO NOT use NKC-125MA with the angle grinder which can NOT be fitted correctly as instructed in the manual.
- NKC-125MA is only for grinding concrete and block. DO NOT use for grinding steel or other materials.
- NKC-125MA must be used with the Vacuum suitable for the concrete dust.
- NKC-125MA is only for 100-125mm Diamond Grinding Cup Wheels. DO NOT use with abrasive wheels.
- Always check NKC-125MA for damage, cracks, or deformation before use.
- DO NOT use NKC-125MA if it is cracked, damaged or bent as this could lead to injury.
- Be sure to wear the protective goggles, dust mask, protective foot wear, earplugs and other protective equipment when working.
- Keep NKC-125MA away from gasoline, solvents, and paraffin.
- Ensure the work piece is securely clamped before working.

Explanation of the pictograms.

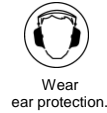

SPECIFICATIONS

Model Code	NKC-125MA	
Suitable Tool	Ø100~125mm (h21mm) Diamond Grinding Cup Wheel	
Weight	470g (Main Unit with adaptor system)	
Work material	Concrete, Block.	
Suitable Angle Grinders	Makita / BOSCH / Dewalt / Milwaukee / Metabo / HiKOKI / FLEX 115-125mm class small angle grinder.	

※Based on the web as of 2022 Sep.

Some special angle grinders (ex. X-LOCK type) may not be installed. Please scan the QR code on the left to check compatibility.

OVER VIEW

[a] Main Unit / [b] Offset Plate / [c] Milwaukee Plate / [d] Wrench / [e] Lock Nut / [f] Base Flange
[g] Spacer T12 / [h] Spacer T10 / [i] Spacer T7 / [k] Joint / [m] Washer / [p] Hook

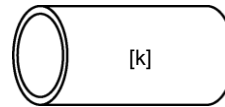
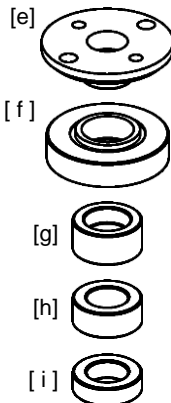
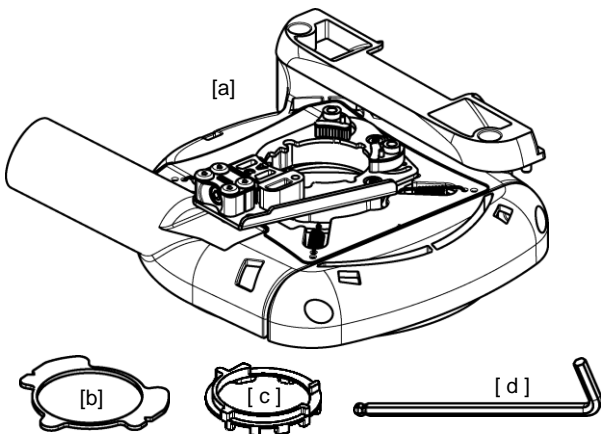

Sold Separately

Sub Plate NKC-SPMA is required separately for the "Large Flange" grinders on the right.

metabo
WEPBA17-125 / WEBA17-125 / WEA17-125 / WEVA15-125 / WA13-125 / WEA11-125 type
WPB13-125 / WB18LTBL11-125 / WVB18LTBL11-125 / WPB18LTBL11-125 type

HiKOKI
G13SB4 / G13SE3 / G13BAWQZ / G13BY / G13YG type

"Large Flange" Grinder

INSTALLATION

1. Detach the Guard from the grinder.

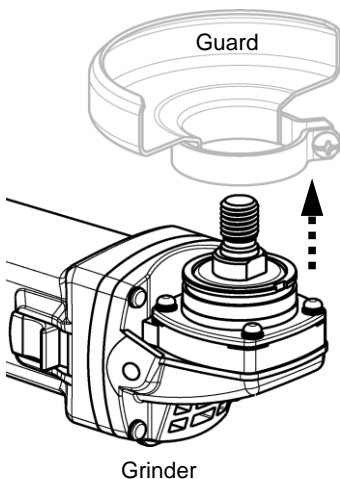

Check the Installation Guide.

Check the instruction video at this QR code.

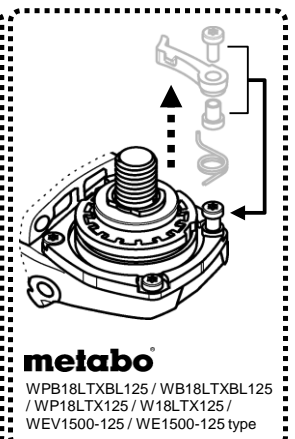
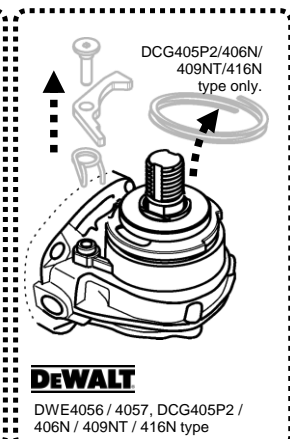
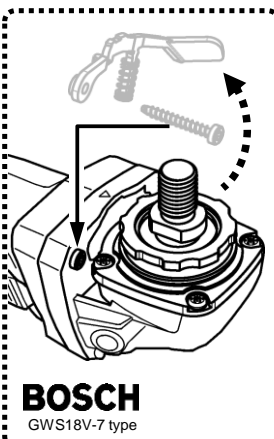
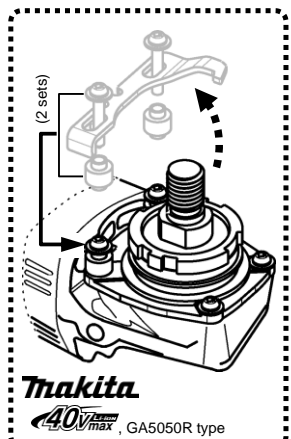

⚠ Above grinder needs its lever and related components detached.

2. Some Grinders need preparation for Upper Bracket and Lower Bracket at [a] Main Unit.

Refer to the Installation Guide.

(Factory default)

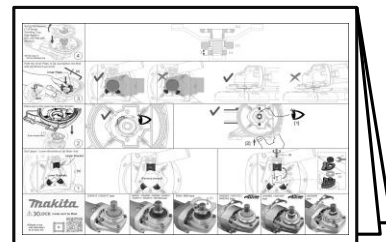
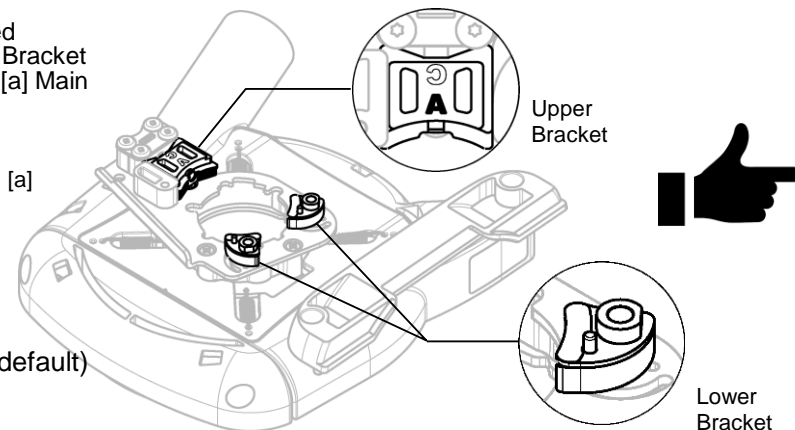

Makita 40V_{max}, GA5050R type
FLEX L1400 125 type

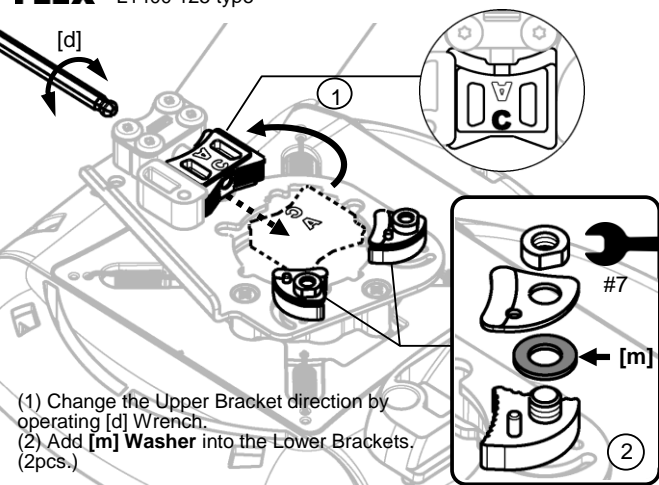

FLEX L1506VR / L9-11 125 / LE9-11 125 / L12-11 125 / L13-10 125-EC / LE14-7 125
INOX / L15-11 125 / LE15-11 125 / L3406VRG / LB17-11 125 type

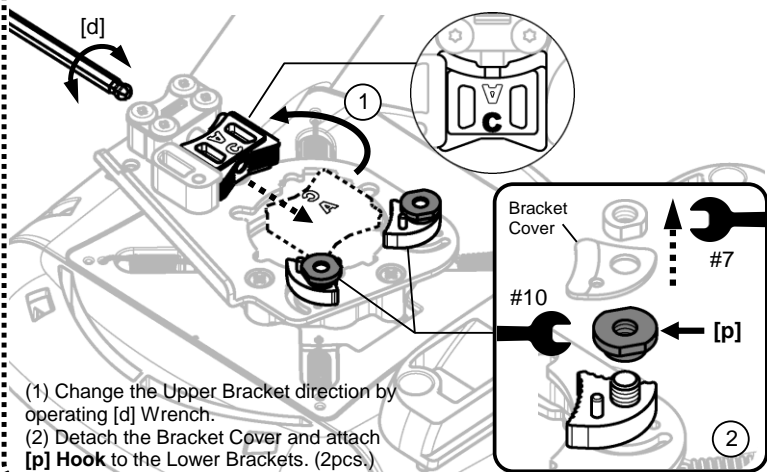

FLEX (OLD type) L3410FR / L3410VR type
Milwaukee HD28AG-125 / AGV17-125 / AG8-125 / AG9-125 type

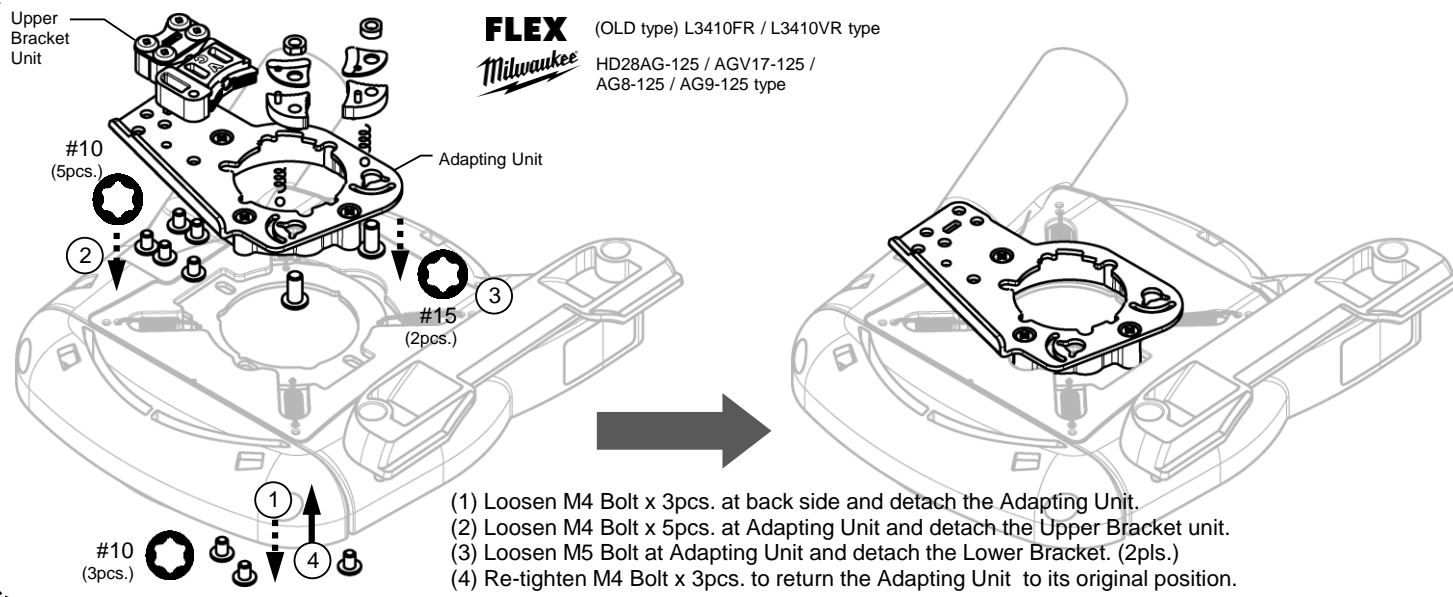

3. Switch the Lower Brackets position when the gearcase size D of the Grinder is larger than 47mm.

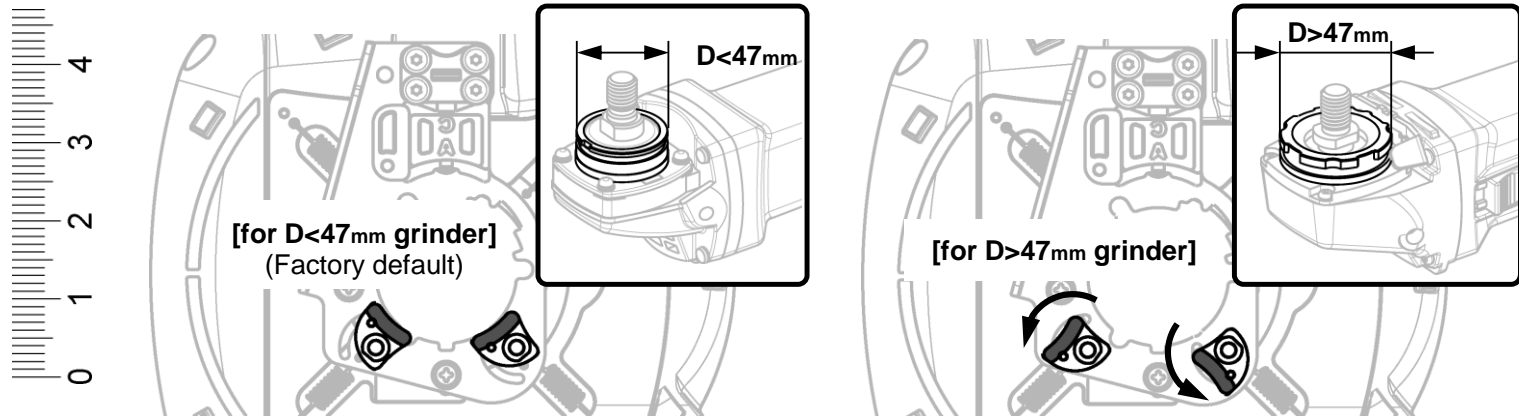

4. Place [a] Main Unit on gearcase of the Grinder.
Some Grinders need [b] Offset Plate or [c] Milwaukee Plate preset on its gearcase.

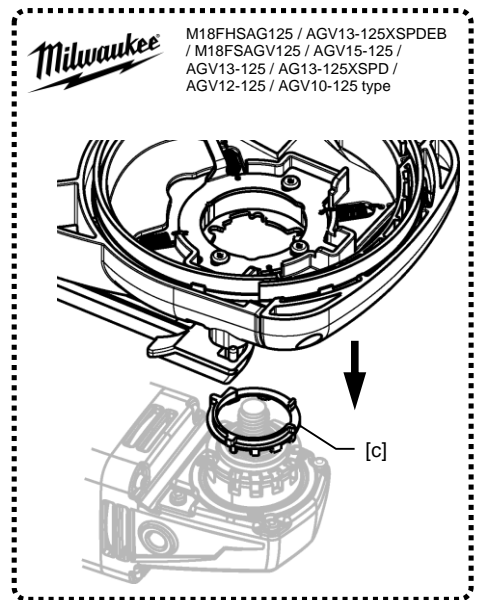
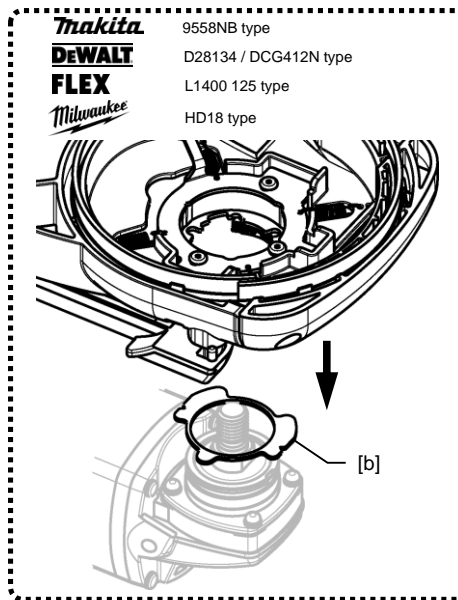
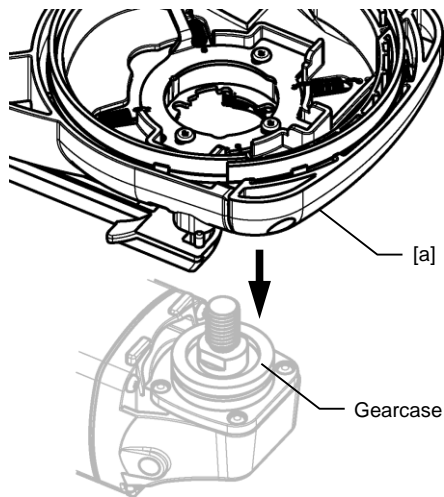

5. Align the center of [a] Main Unit and Spindle, then push [a] Main Unit upward until it stops.

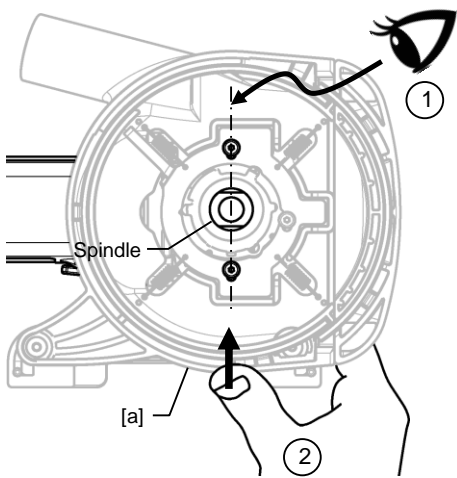

(For some Grinders, just match the shapes of the fitting area)

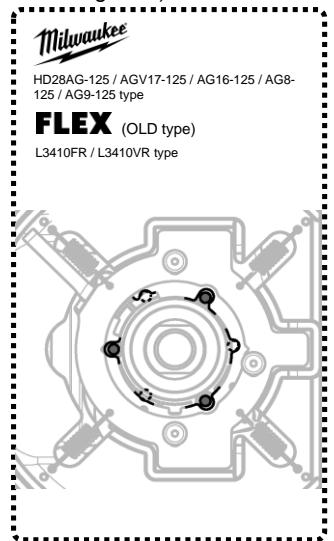
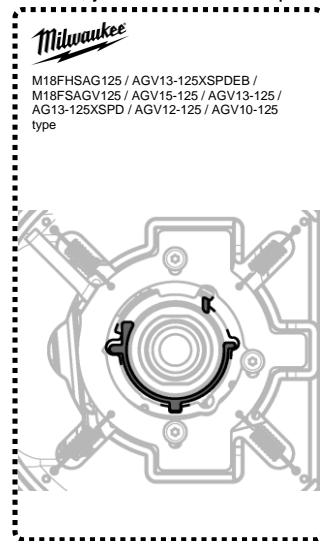
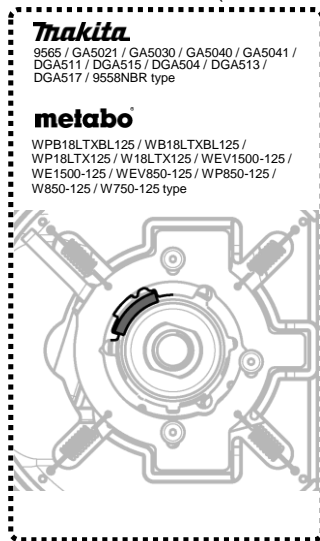

6. Hold the Inner Plate at [a] Main Unit and tighten the Bolt with [d] Wrench securely.

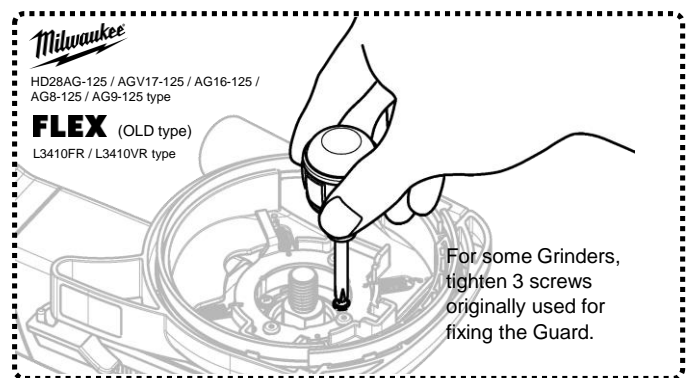
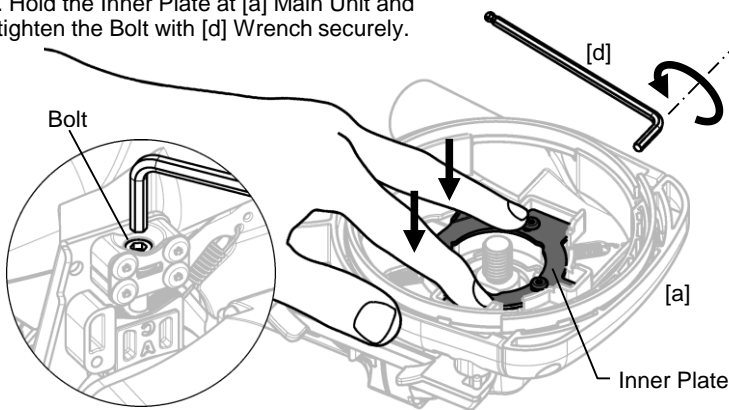

7. Set [g / h / i] Spacer, [f] Flange, Cup Wheel into the spindle then tighten [e] Lock Nut by Wrench.

※Use proper Spacer [g / h / i] to keep the bottom space 1~5mm under the Cup Wheel.

Refer to the Installation Guide.

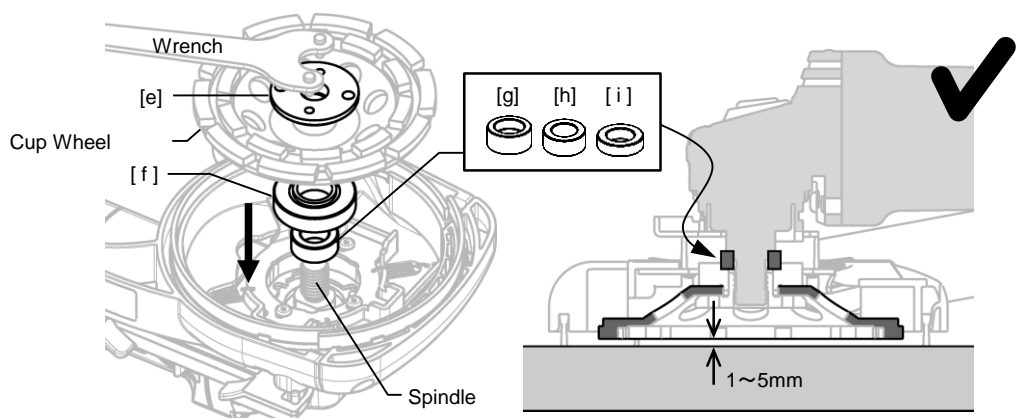
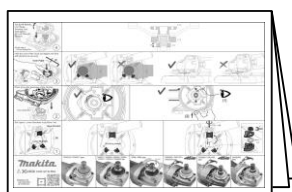

⚠ If [f] Flange is off center, loosen M4 Bolt x 3pcs. at back side and adjust the position of [a] Main Unit.
 ※Re-tighten 3 screws securely after adjustment.

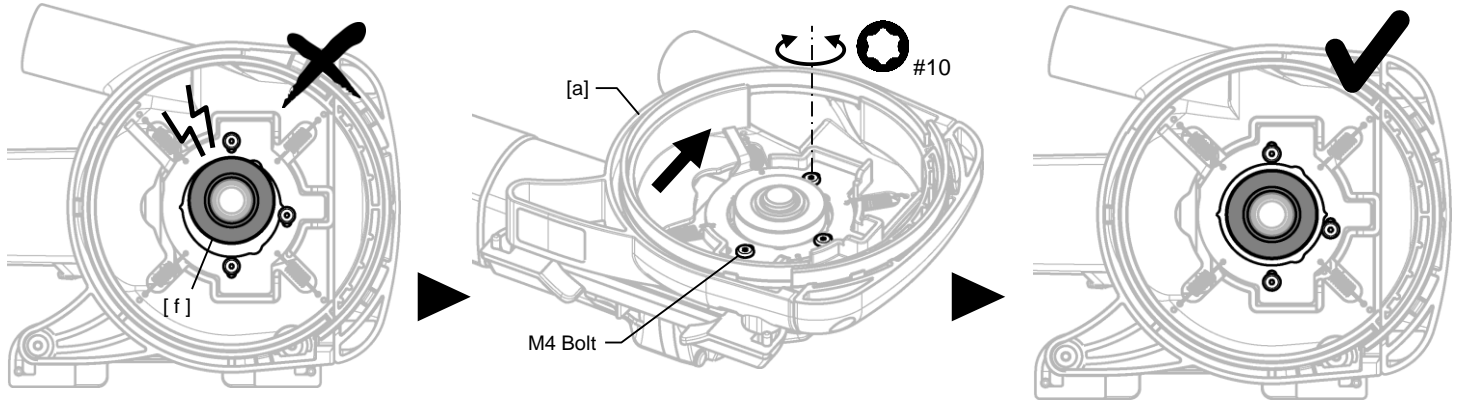

8. Hold [a] Main Unit and connect the Vacuum Hose into the Duct with [k] Joint.

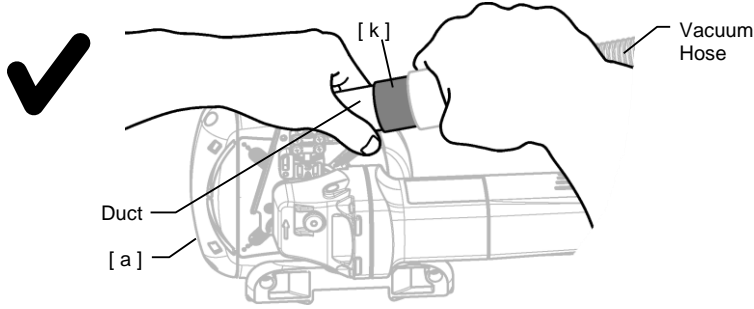

⚠ Do NOT hold the Grinder when connecting the Vacuum Hose.

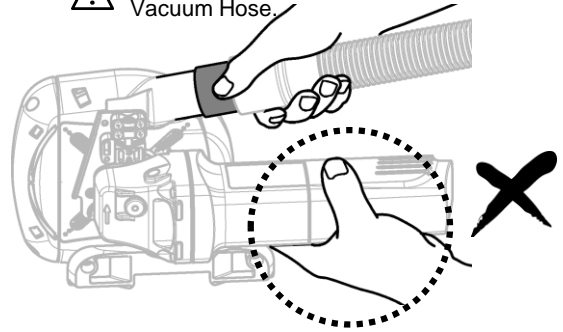

9. Attach the Handle to the Grinder.

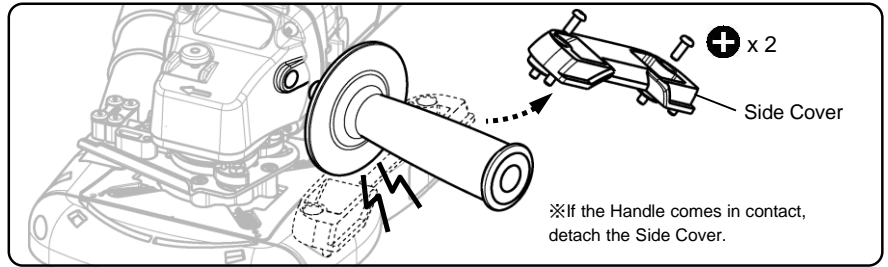
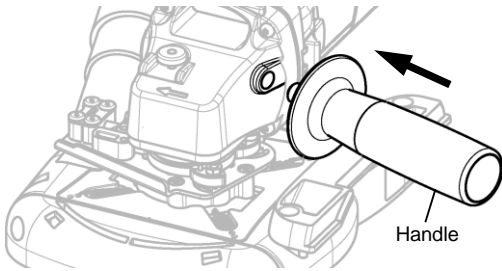

SURFACE GRINDING

1. Securely hold the Grinder and Handle.
2. Turn on the switch of the vacuum and Grinder.
3. Place [a] Main Unit on material slowly, then move the Grinder toward the grinding direction.

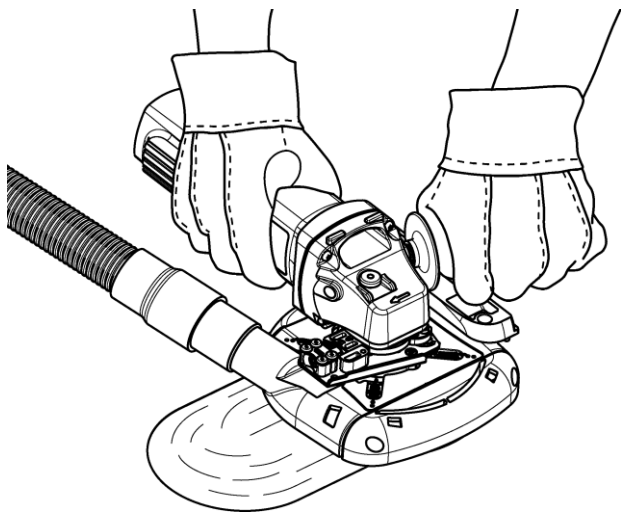

CORNER GRINDING

1. Detach Front Cover and Side Cover, then replace their positions.
2. Hereafter same as "SURFACE GRINDING" on the left.

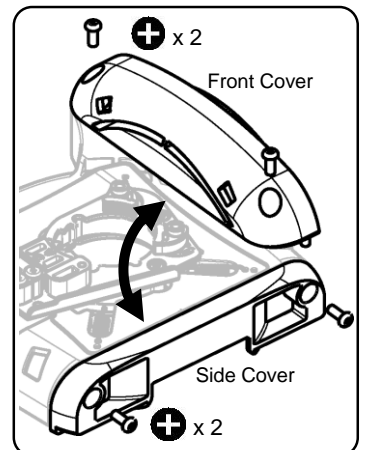
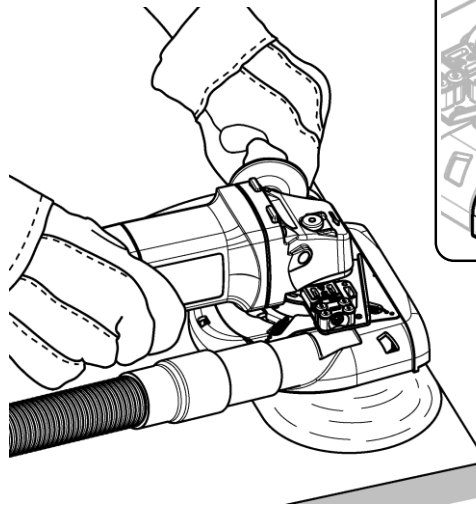

Head Office in Japan
NAKAYA CO.,LTD.
 1313-92 Yanagisawa, Sanjo, Niigata, Japan



20th-Oct. 2022

Eto Naoya
 Eto Naoya
 Managing Director