

Set [g/h/i] Spacer, [f] Flange, Grinding Cup, then tighten [e] Lock-Nut with Wrench.

※In the case of h21mm Grinding Cup.

4

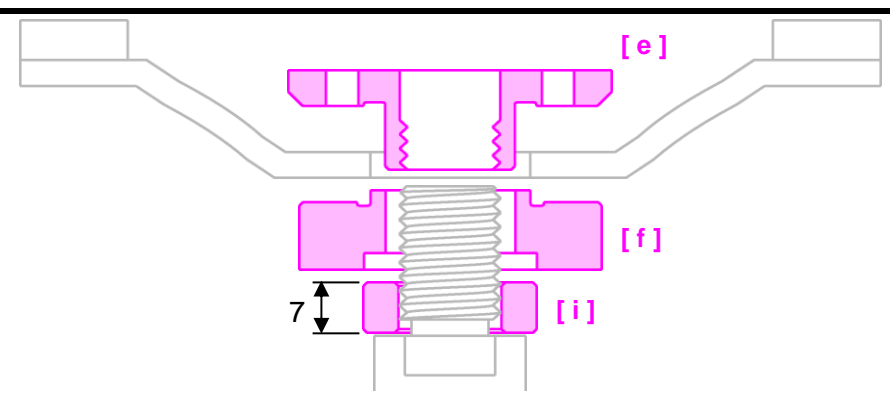

Hold the Inner Plate of [a] and tighten the Bolt with [d] Wrench securely.

Inner Plate

Bolt

d

3

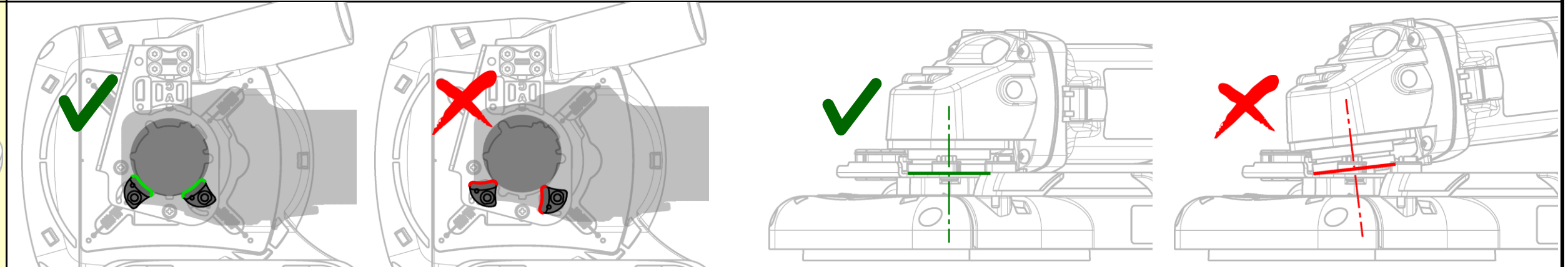

Place [a] on the gearcase of the Grinder.

Some models ONLY.

b

2

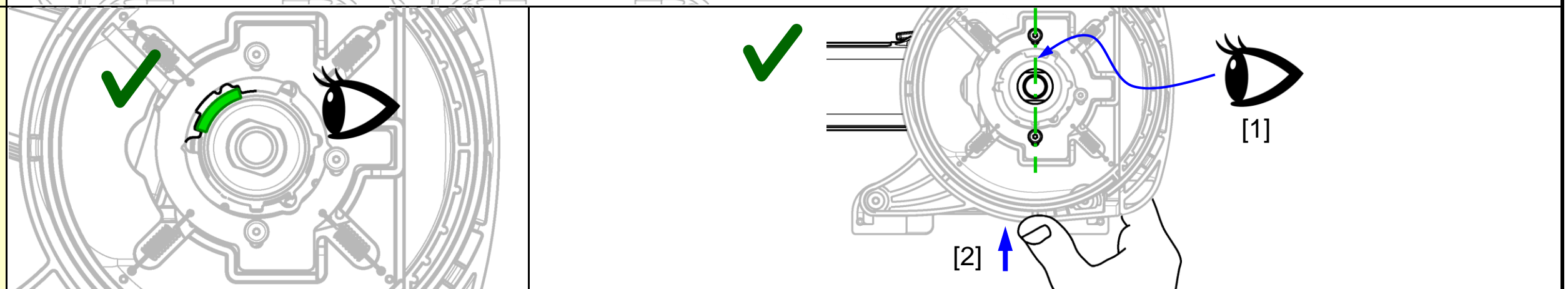

Set Upper / Lower Brackets at [a] Main Unit.

Upper Bracket

Lower Brackets

a

1

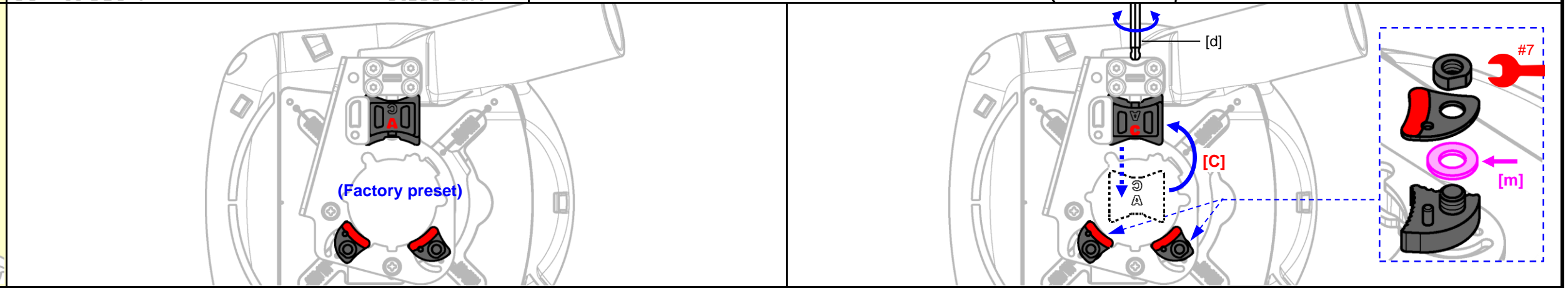

Makita

⚠ XLOCK model can't be fitted.

▶

QR Code

※Based on the web information as of 2022 Jan.

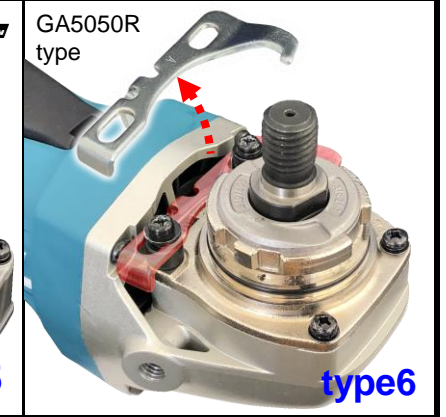
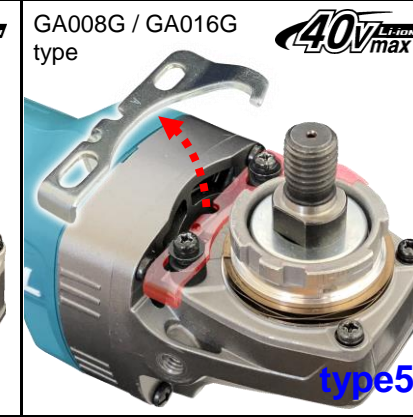
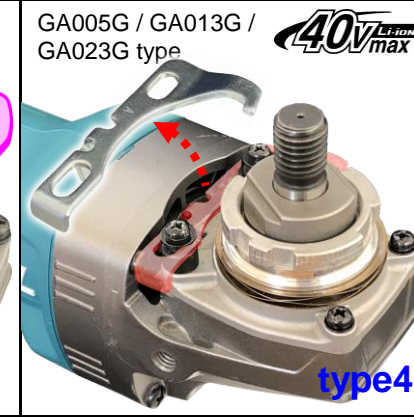
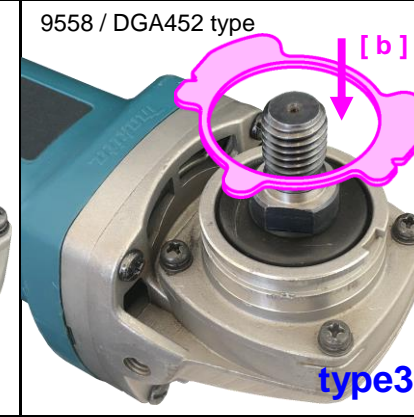
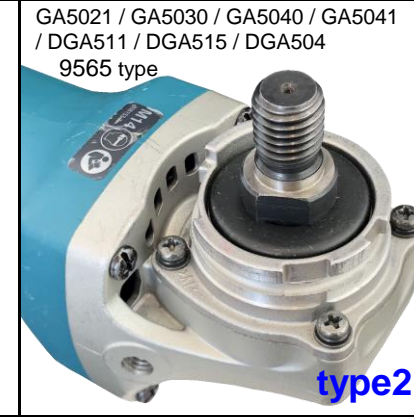
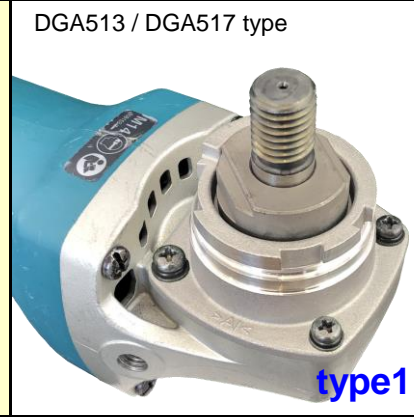

Set [g/h/i] Spacer, [f] Flange, Grinding Cup, then tighten [e] Lock-Nut with Wrench.

※In the case of h21mm Grinding Cup.

4

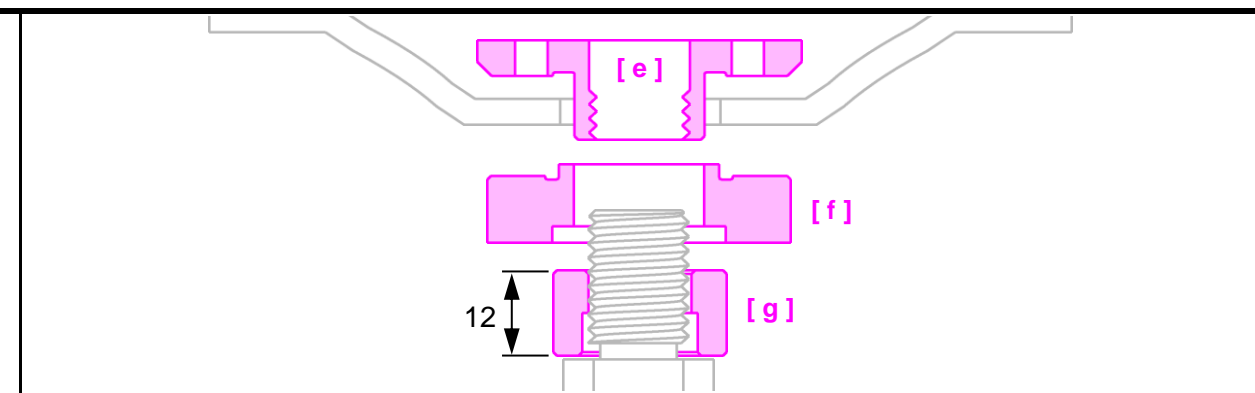
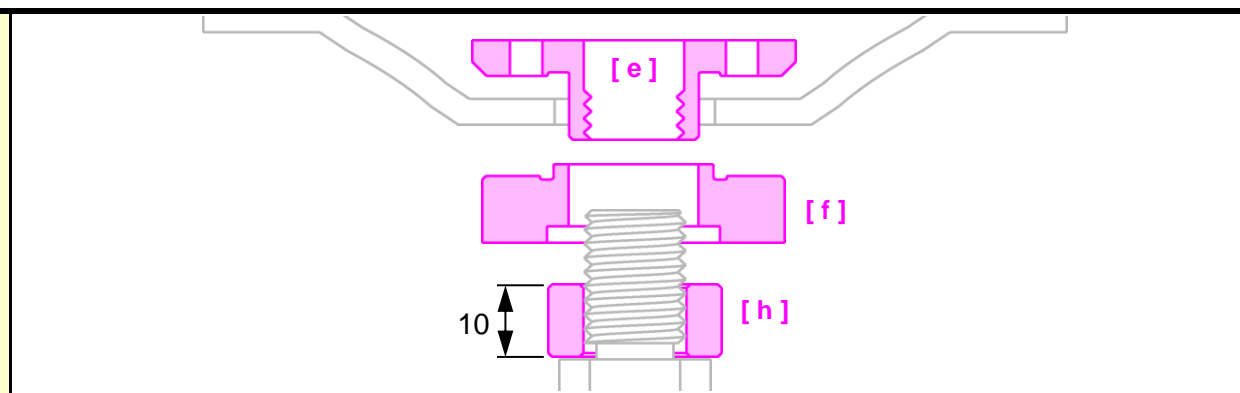

Hold the Inner Plate of [a] and tighten the Bolt with [d] Wrench securely.

Inner Plate

Bolt

3

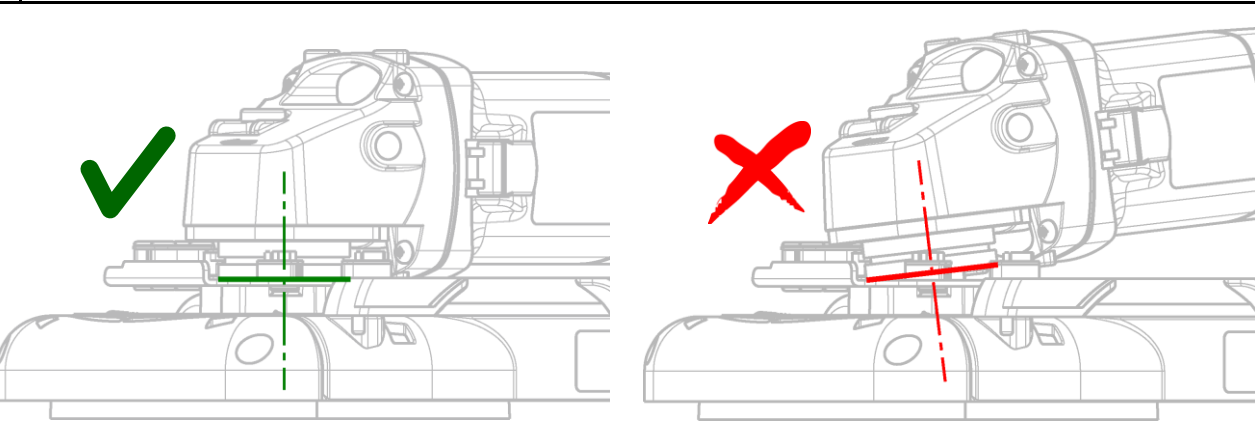
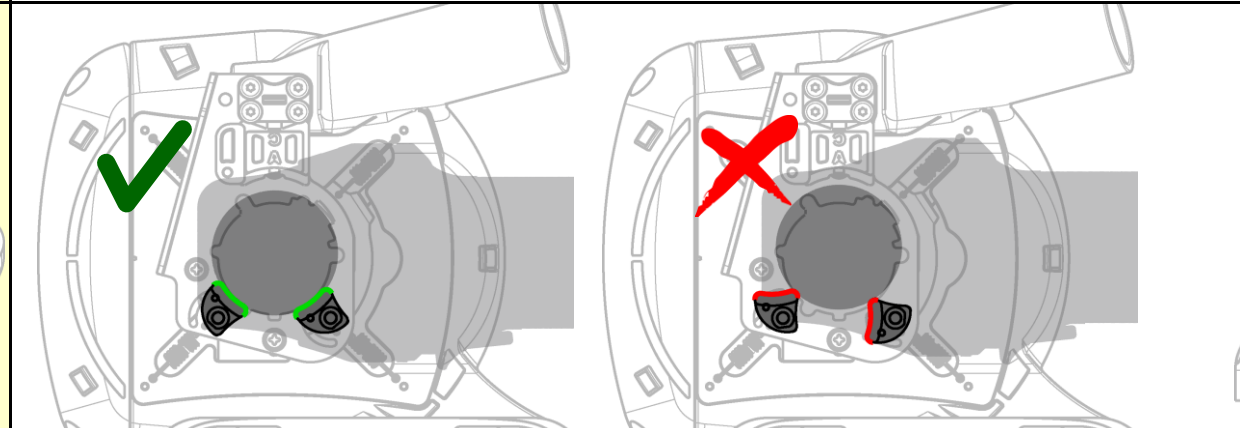

Place [a] on the gearcase of the Grinder.

2

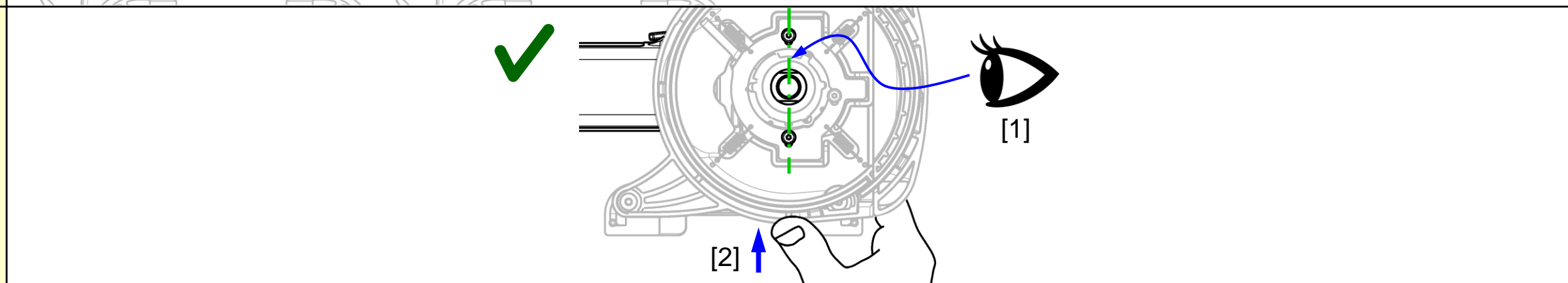

Set Upper / Lower Brackets at [a] Main Unit.

Upper Bracket

Lower Brackets

[a]

1

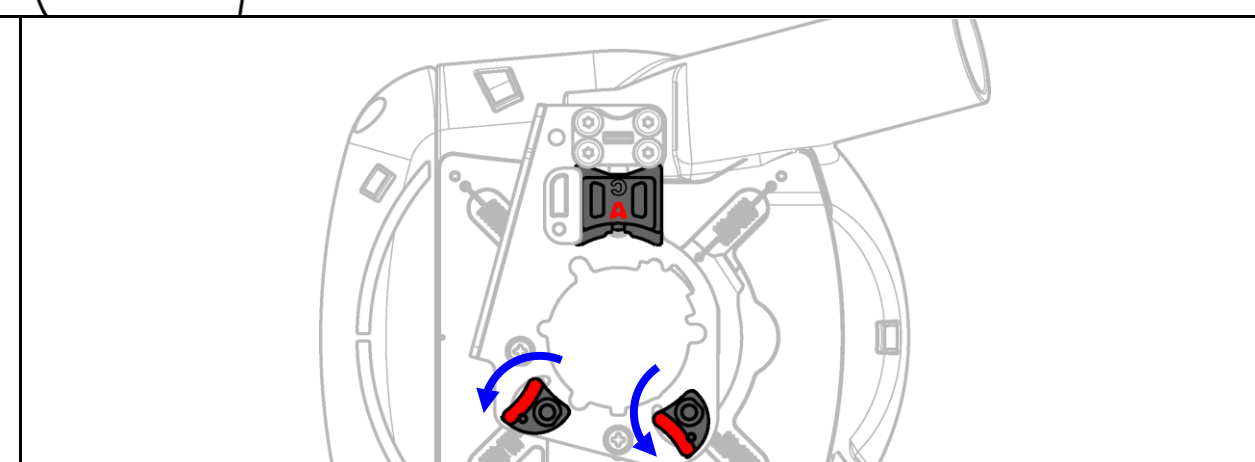
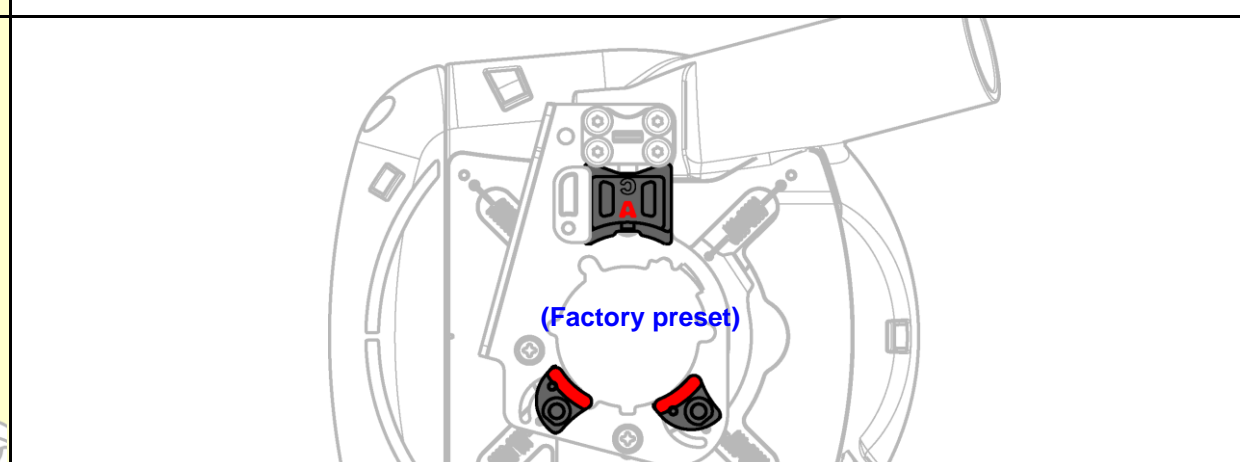

BOSCH

⚠️ XLOCK model can't be fitted.

※Based on the web information as of 2022 Jan.

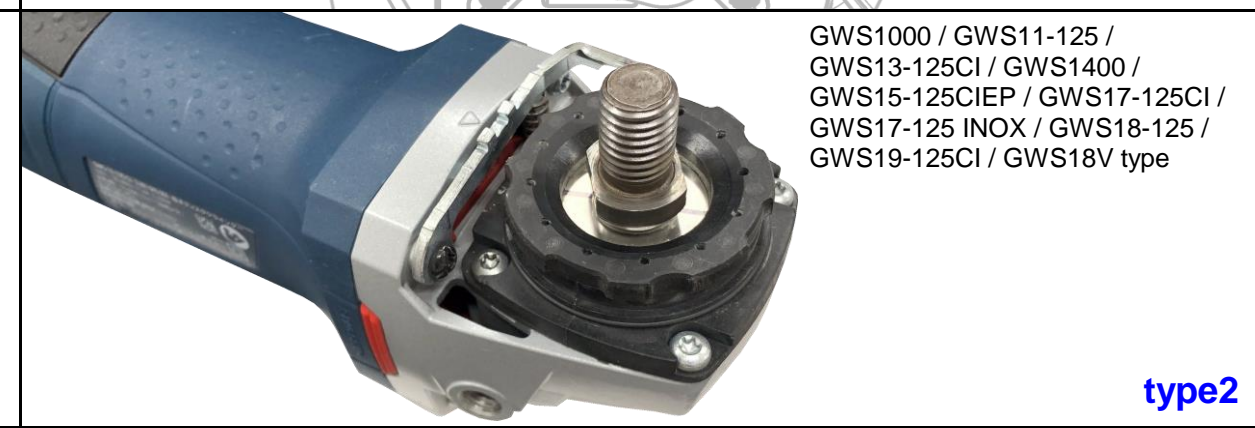

Set [g/h/i] Spacer, [f] Flange, Grinding Cup, then tighten [e] Lock-Nut with Wrench.

※In the case of h21mm Grinding Cup.

4

Hold the Inner Plate of [a] and tighten the Bolt with [d] Wrench securely.

Inner Plate

Bolt

3

Place [a] on the gearcase of the Grinder.

[b] Some models ONLY.

2

Set Upper / Lower Brackets at [a] Main Unit.

Upper Bracket

Lower Brackets

[a]

1

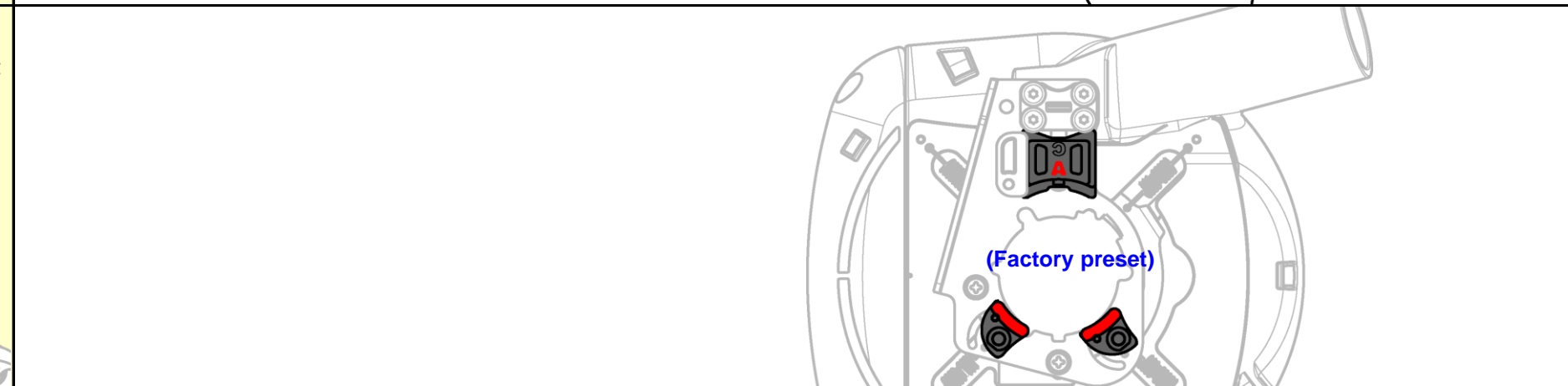
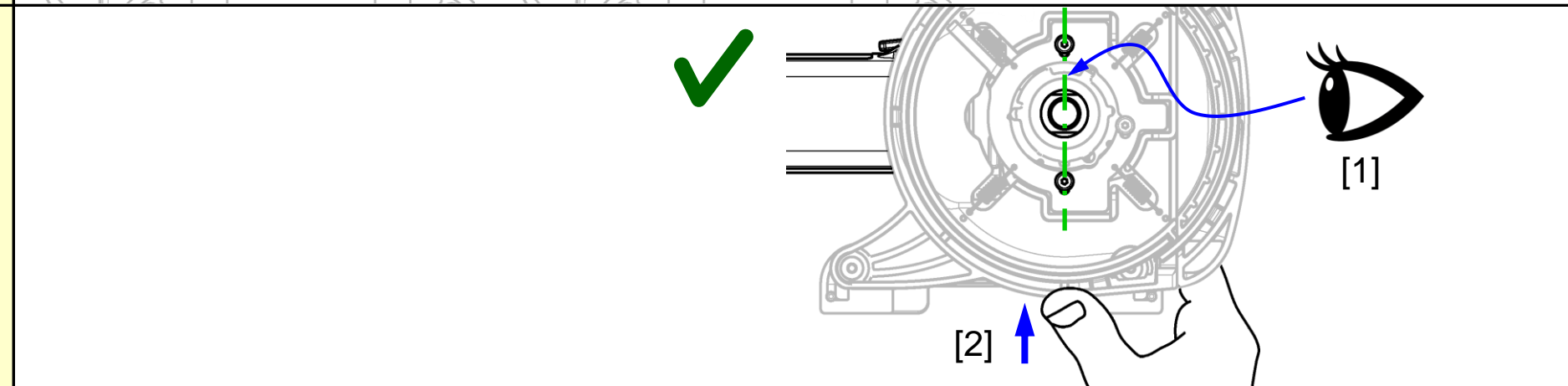
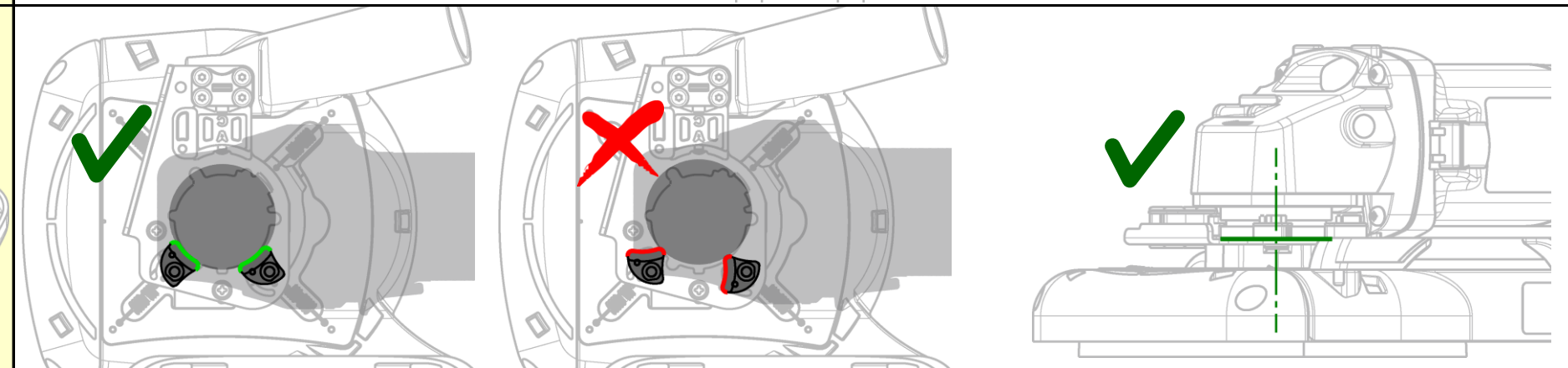
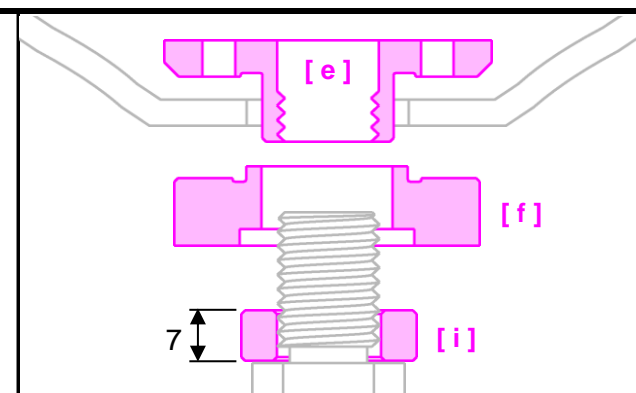
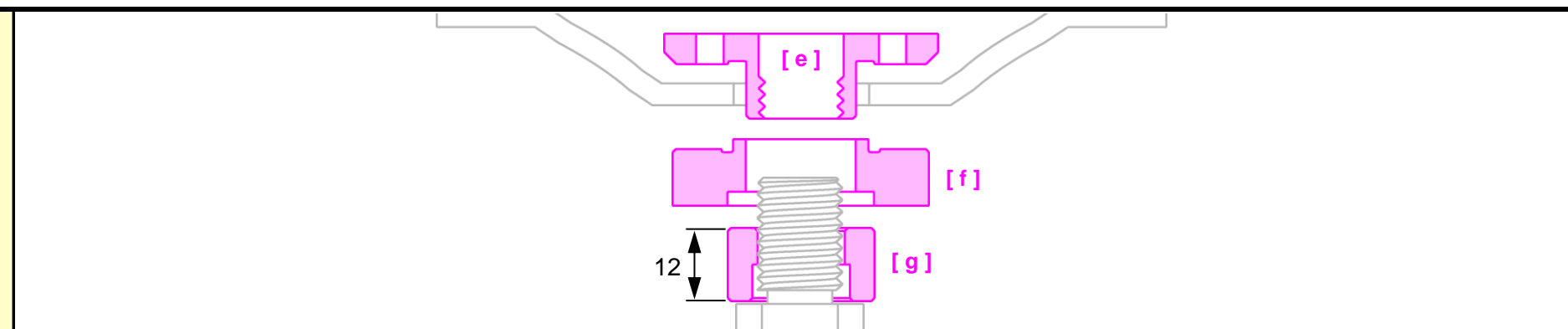

⚠ D28137 / DCG405FN can't be fitted.

※Based on the web information as of 2022 Jan.

DWE4203 / 4206 / 4207 / 4217 / 4237K / 4257 / 4277 / 4357 / 4369, DCG414NT / 418NT type

type1

DWE4056 / 4057 type

type2

D28134 / DCG412N type

[b]

type3

DCG405 / 406 / 409 / 416 type
※Except DCG405FN

type4

Set [g/h/i] Spacer, [f] Flange, Grinding Cup, then tighten [e] Lock-Nut with Wrench.

※In the case of h21mm Grinding Cup.

4

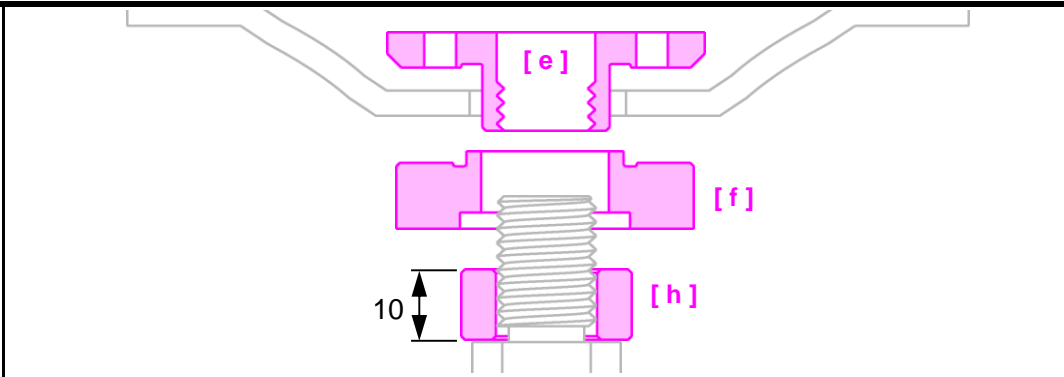
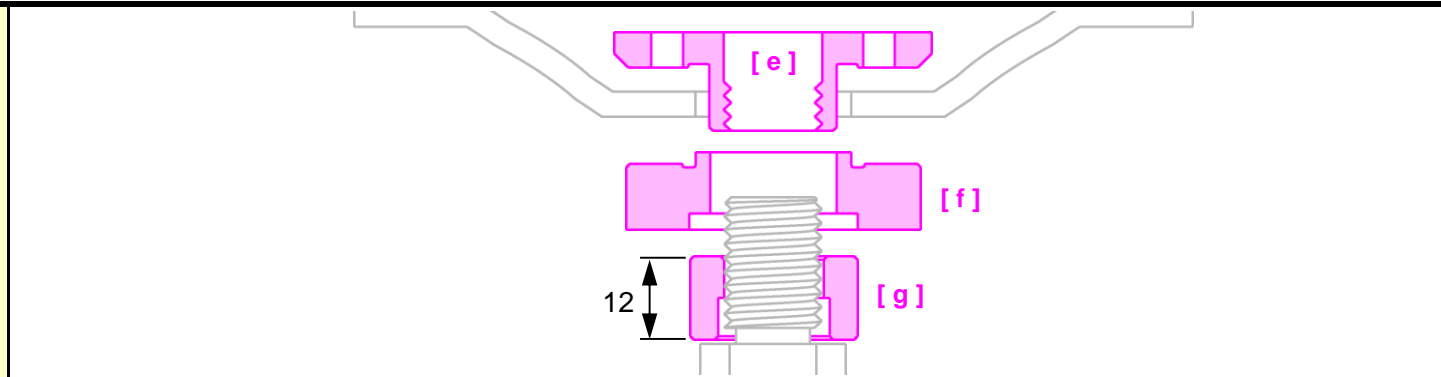

Hold the Inner Plate of [a] and tighten the Bolt with [d] Wrench securely.

Inner Plate [a]

Bolt [d]

3

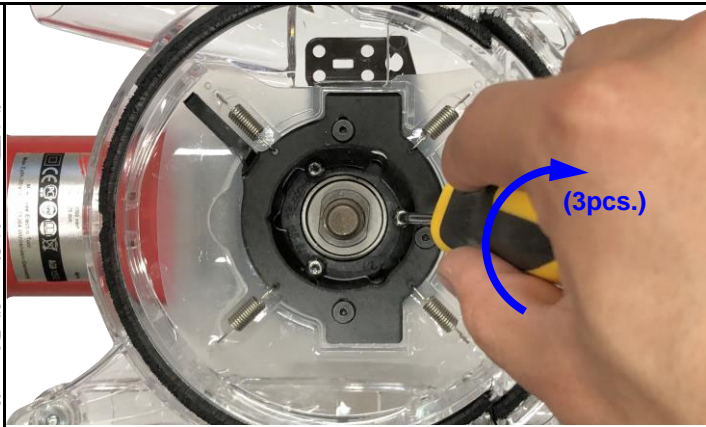
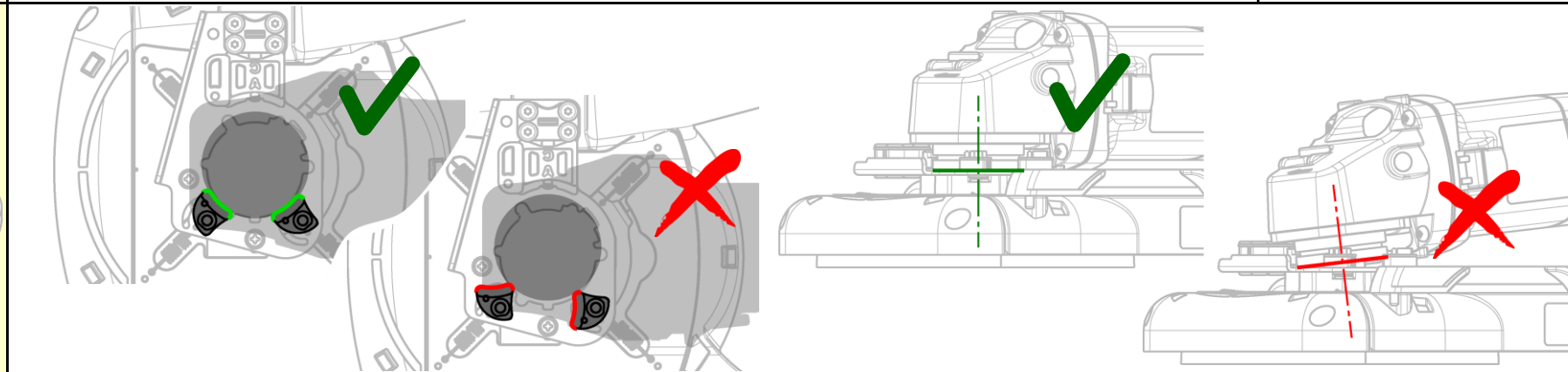

Place [a] on the gearcase of the Grinder.

[a]

[b/c] (Some models ONLY.)

2

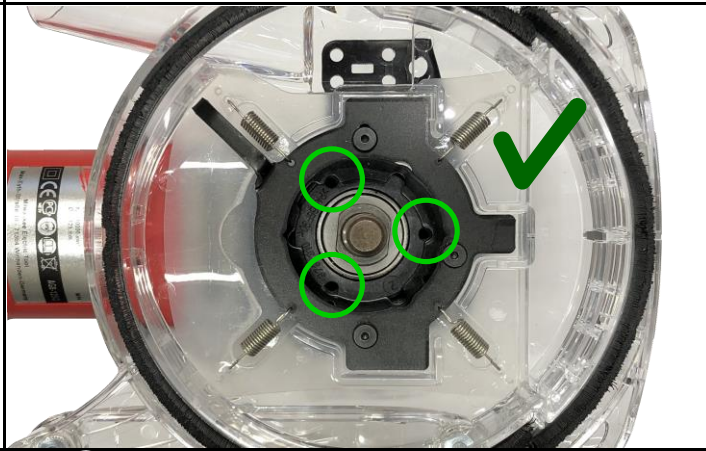
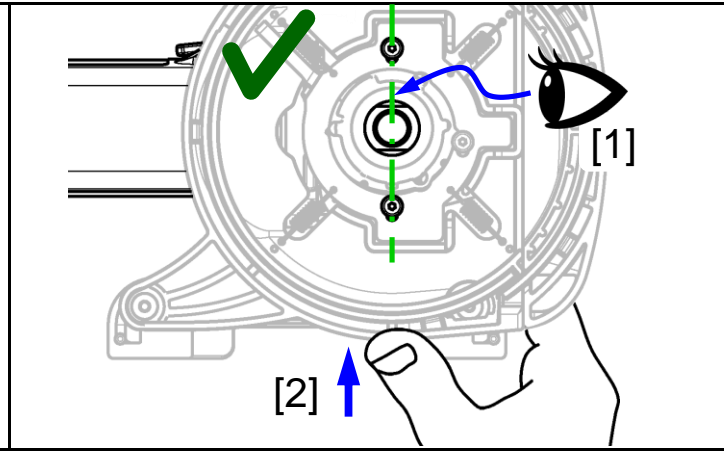
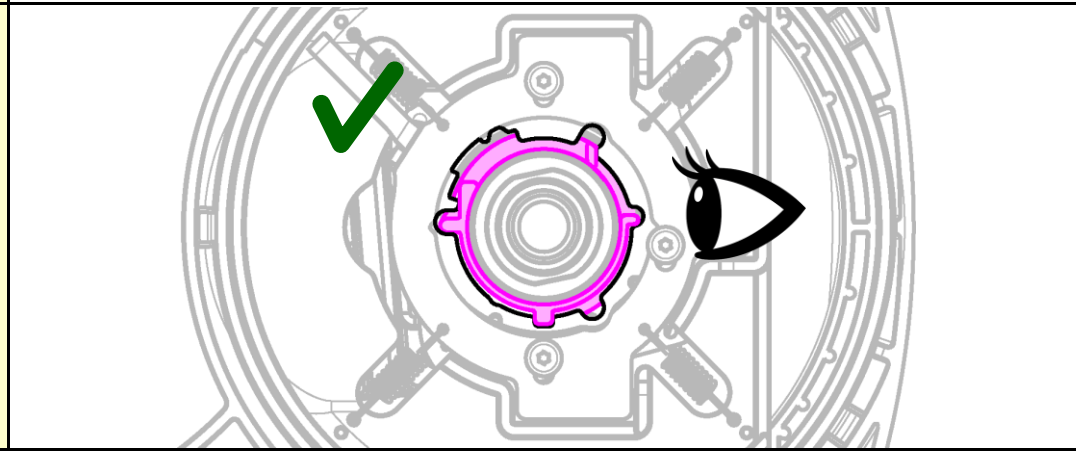

Set Upper / Lower Brackets at [a] Main Unit.

Upper Bracket [a]

Lower Brackets

1

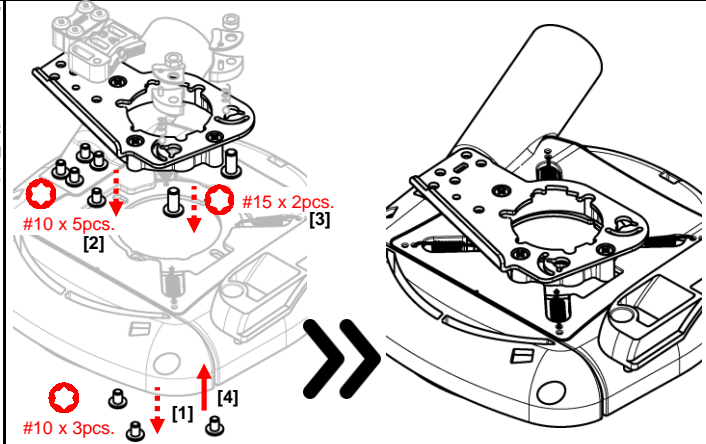
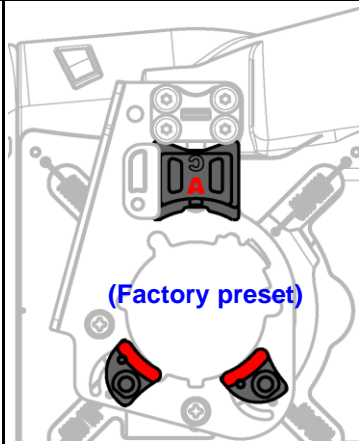
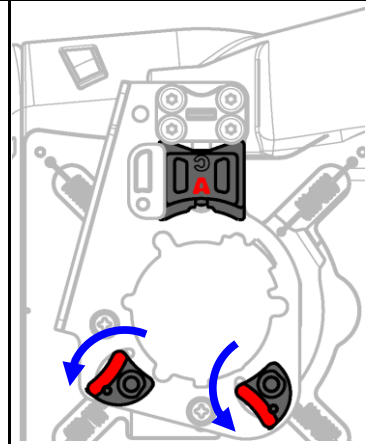
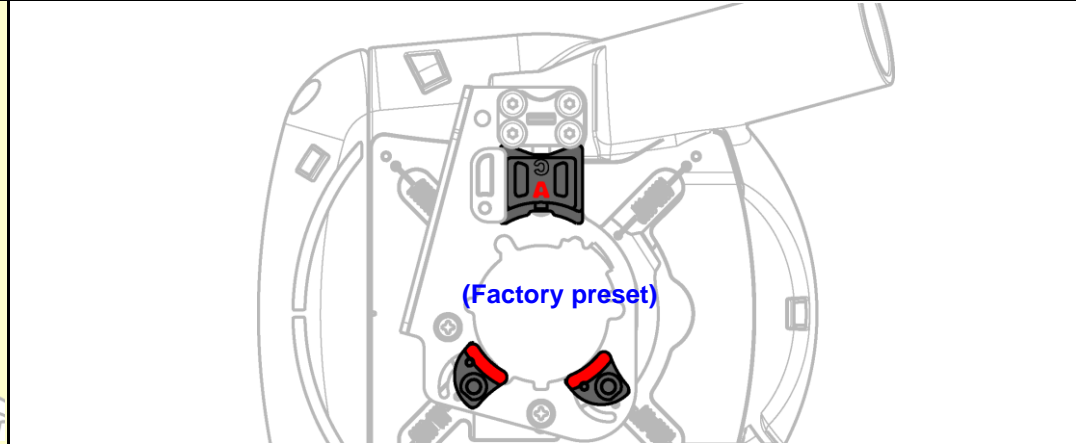

AGV10-125EK, AG10-125EK, AG800-125EK type can't be fitted.

※Based on the web information as of 2022 Jan.

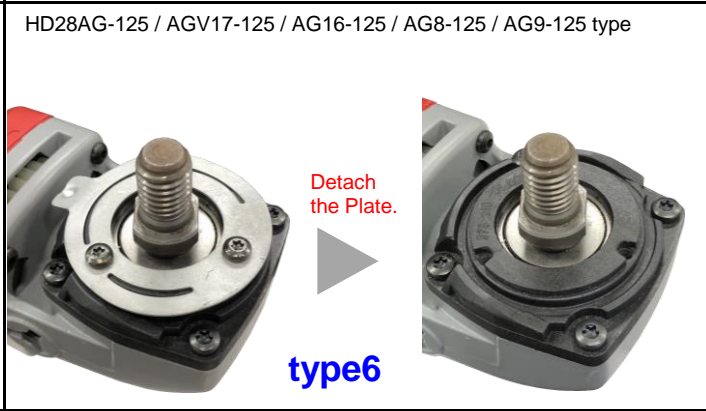
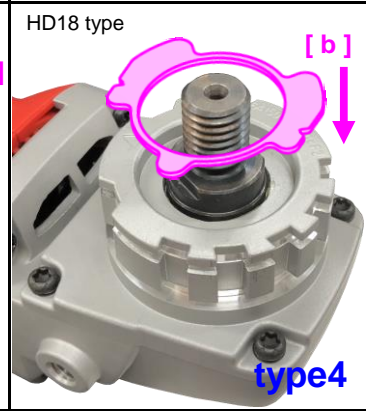
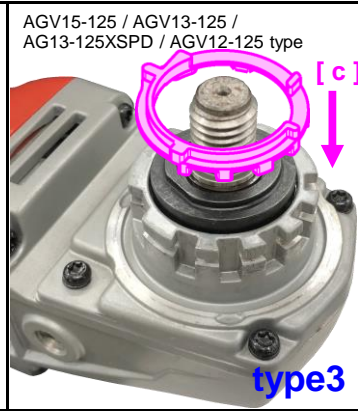
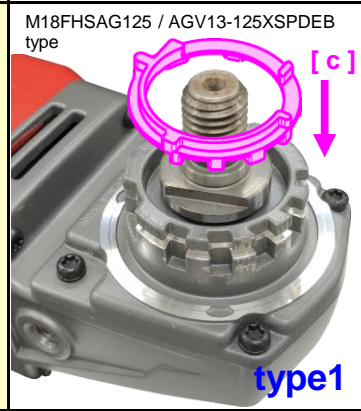

Set [g/h/i] Spacer, [f] Flange, Grinding Cup, then tighten [e] Lock-Nut with Wrench.

※In the case of h21mm Grinding Cup.

4

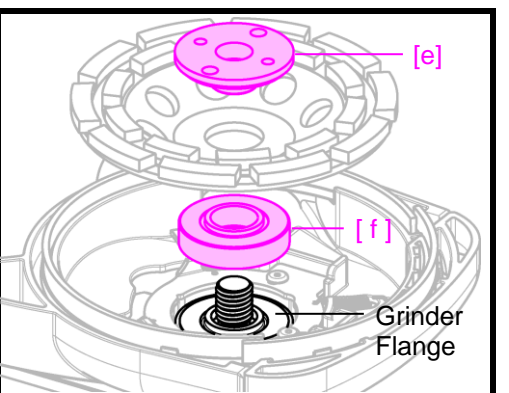
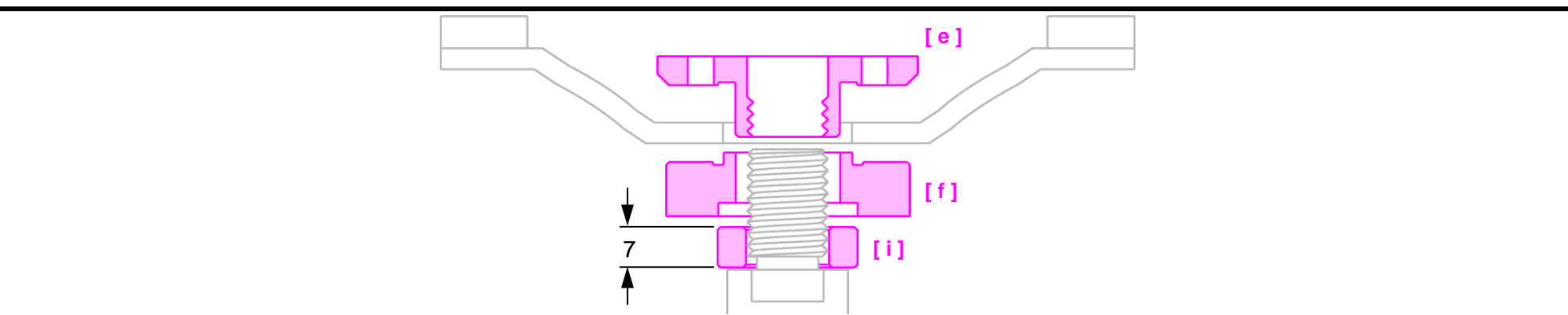

Hold the Inner Plate of [a] and tighten the Bolt with [d] Wrench securely.

Inner Plate

Bolt

3

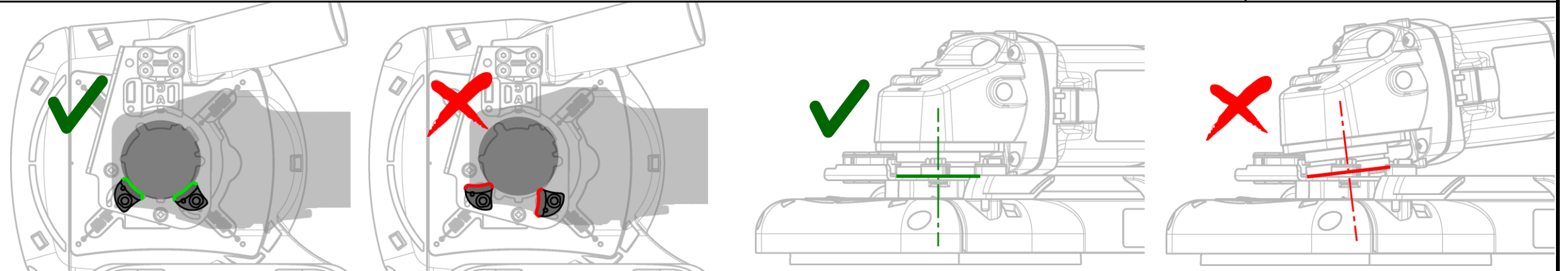

Place [a] on the gearcase of the Grinder.

2

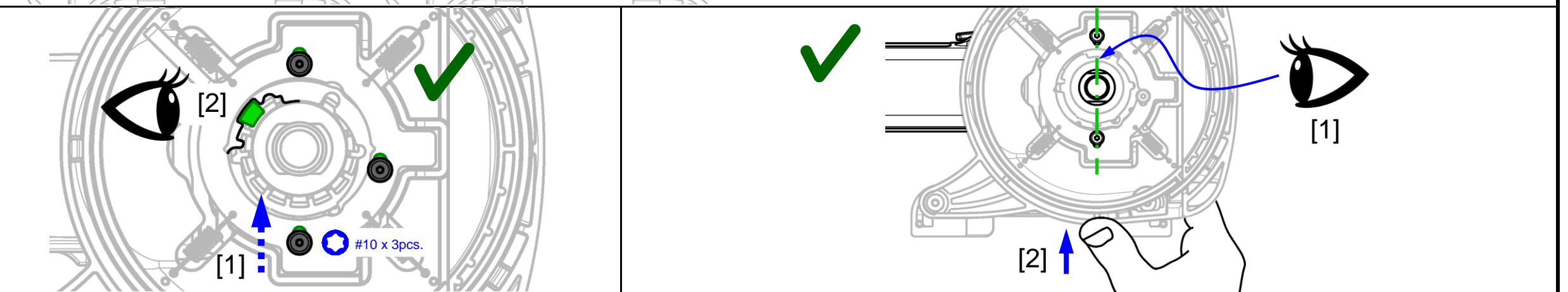

Set Upper / Lower Brackets at [a] Main Unit.

Upper Bracket

Lower Brackets

[a]

1

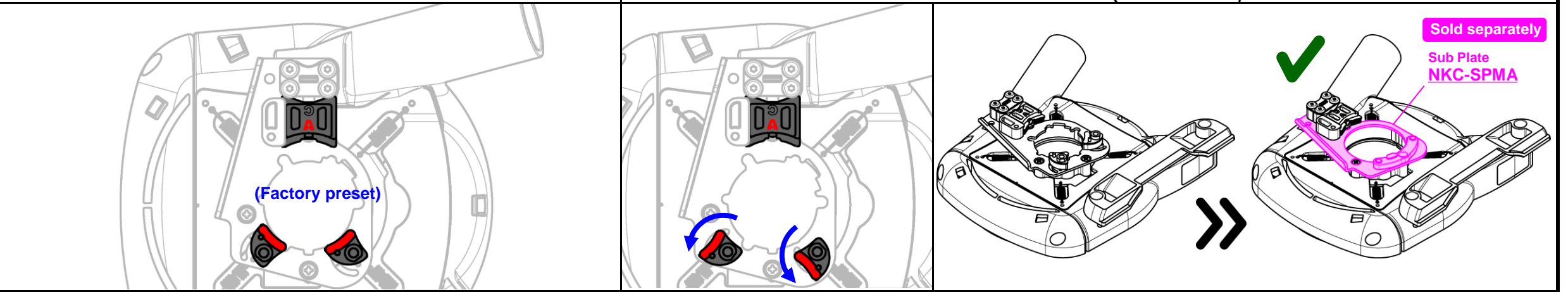

metabo®

※Based on the web information as of 2022 Jan.

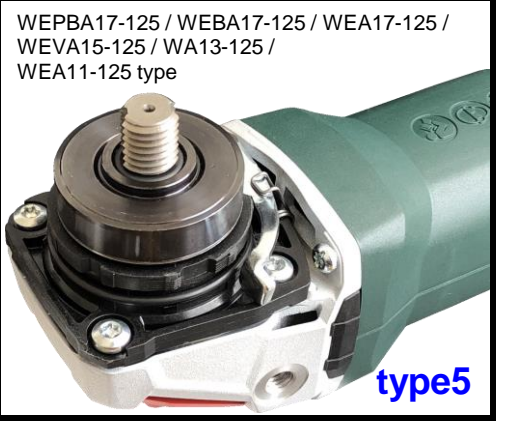
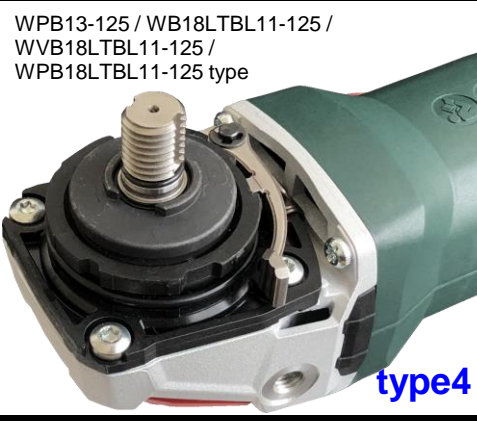
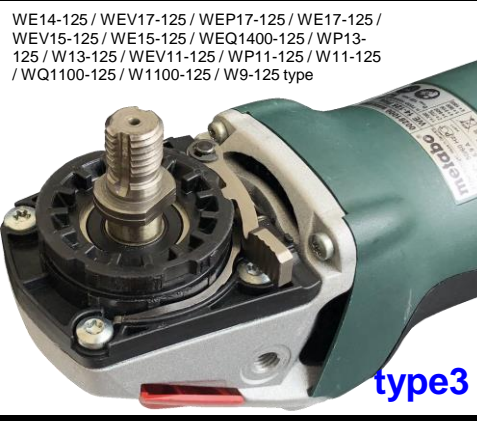
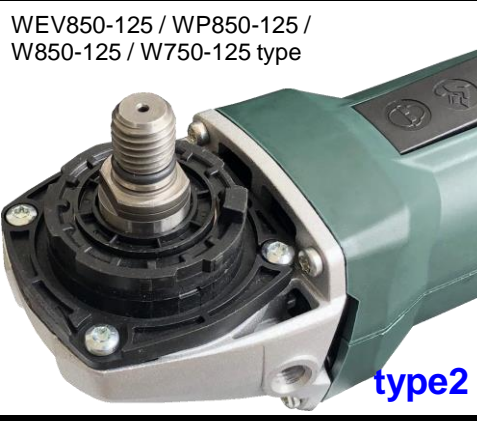
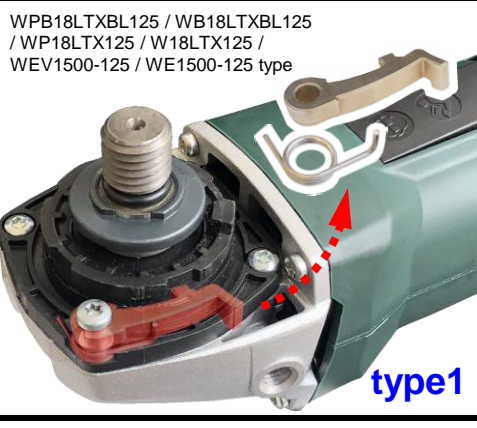

Set [g/h/i] Spacer, [f] Flange, Grinding Cup, then tighten [e] Lock-Nut with Wrench.

※In the case of h21mm Grinding Cup.

4

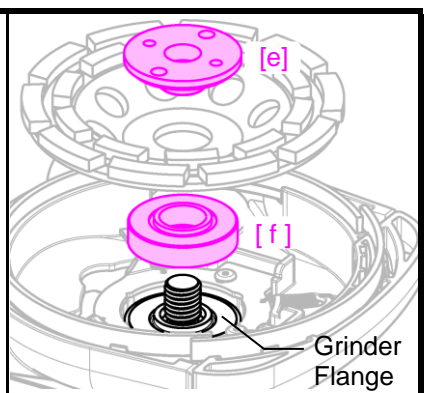
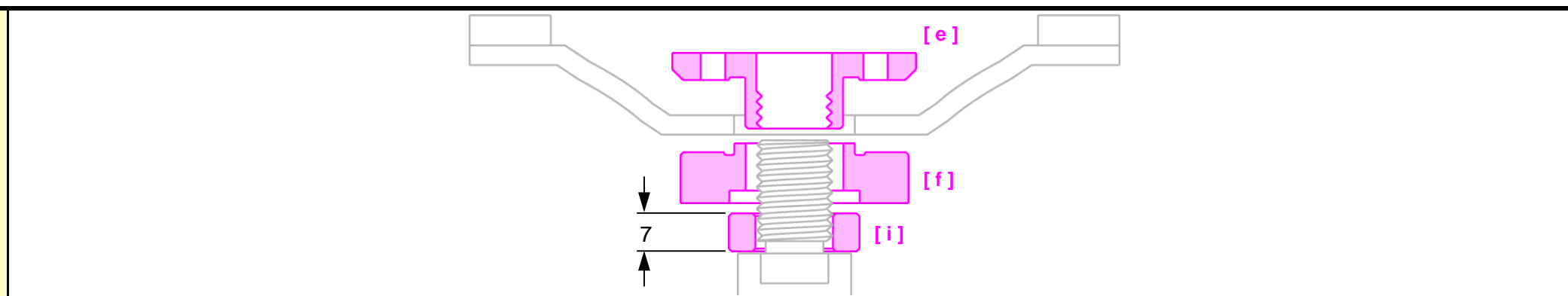

Hold the Inner Plate of [a] and tighten the Bolt with [d] Wrench securely.

Inner Plate

Bolt

3

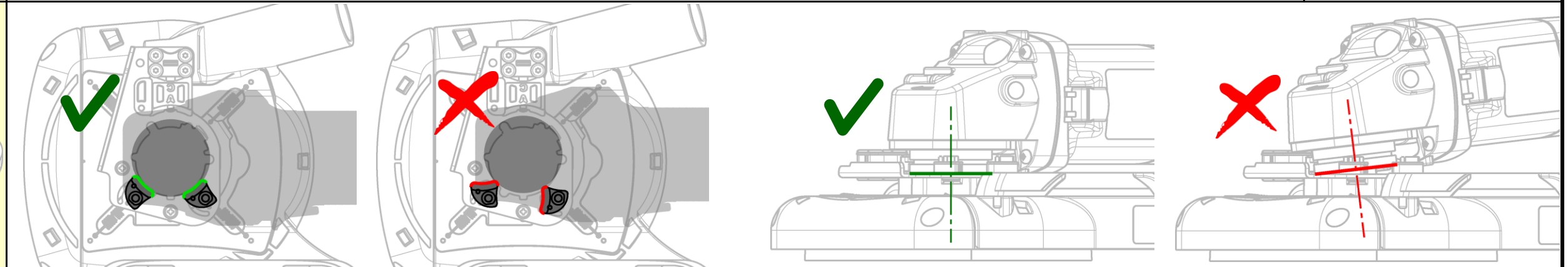

Place [a] on the gearcase of the Grinder.

2

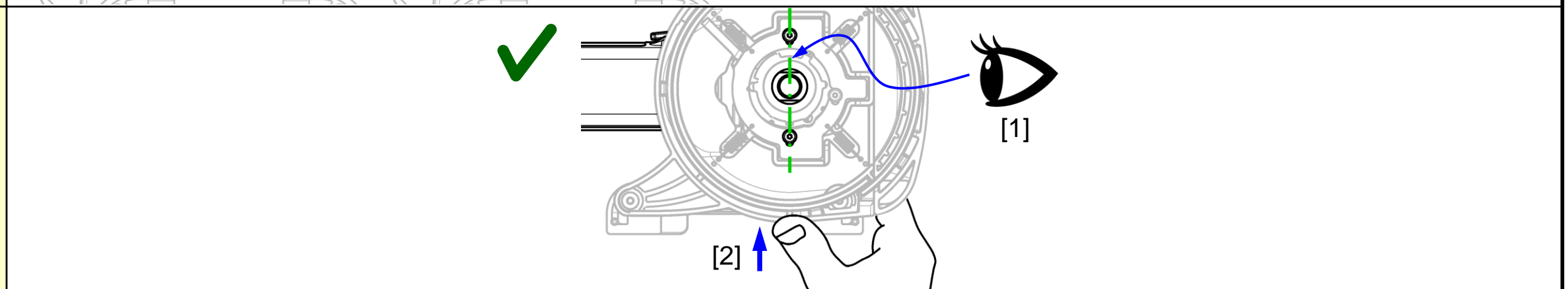

Set Upper / Lower Brackets at [a] Main Unit.

Upper Bracket

Lower Brackets

[a]

1

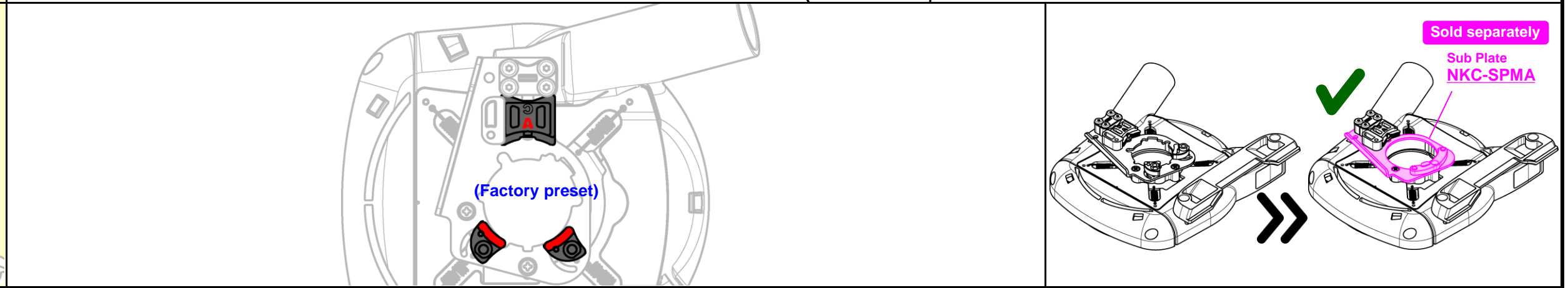

HIKOKI

※Based on the web information as of 2022 Jan.

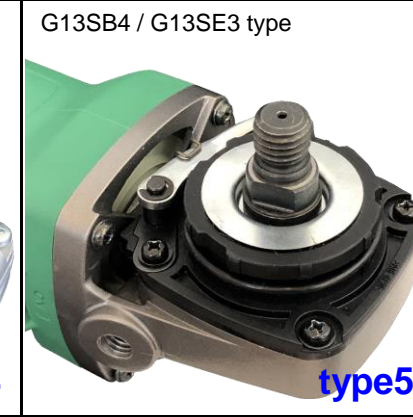
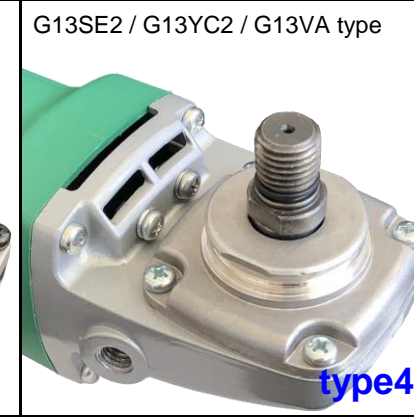
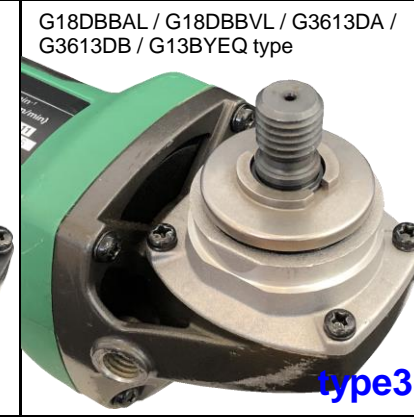
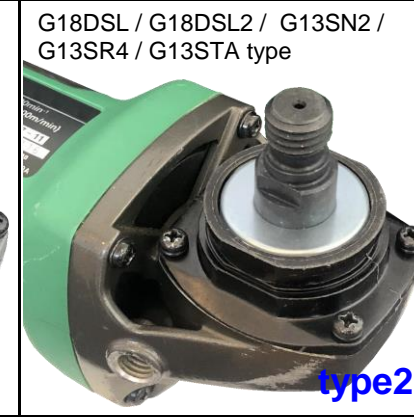

Set [g/h/i] Spacer, [f] Flange, Grinding Cup, then tighten [e] Lock-Nut with Wrench.

※In the case of h21mm Grinding Cup.

4

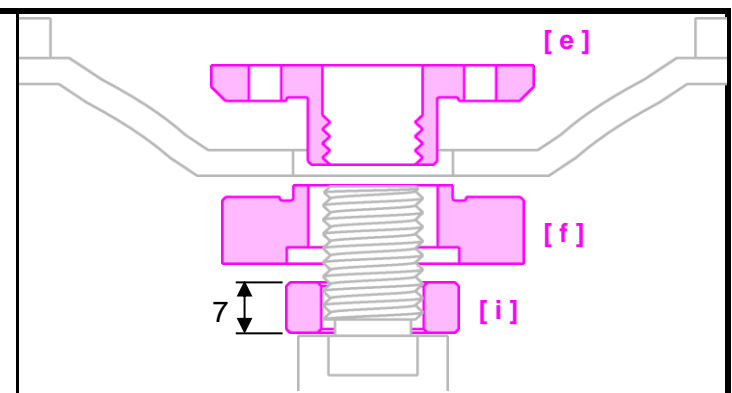
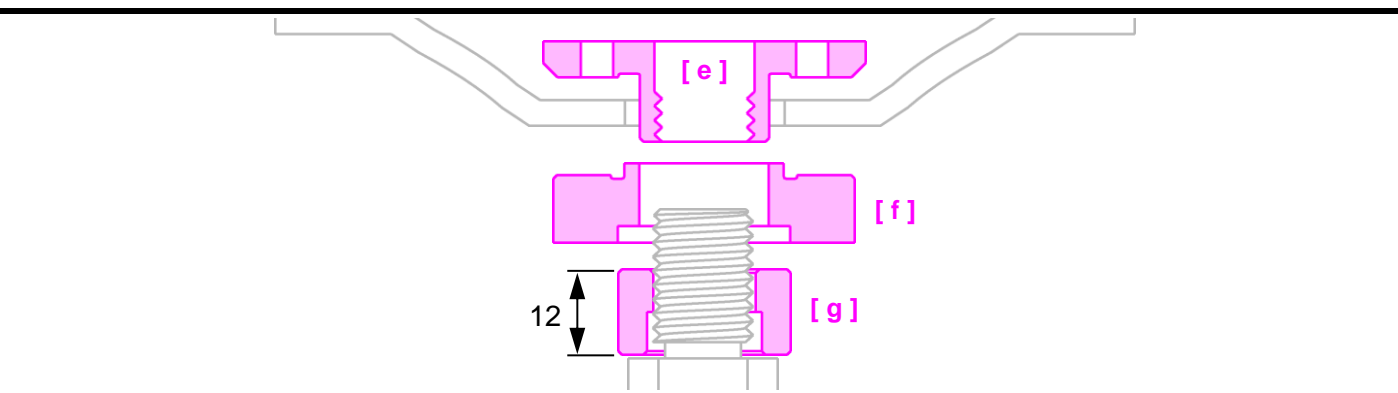
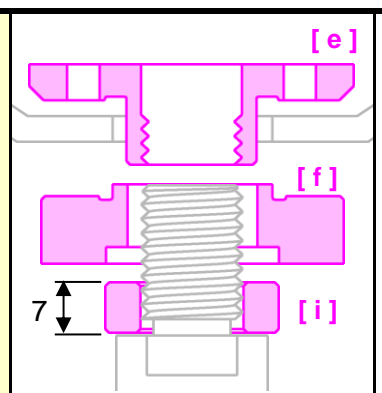

Hold the Inner Plate of [a] and tighten the Bolt with [d] Wrench securely.

Inner Plate [a]
Bolt [d]

3

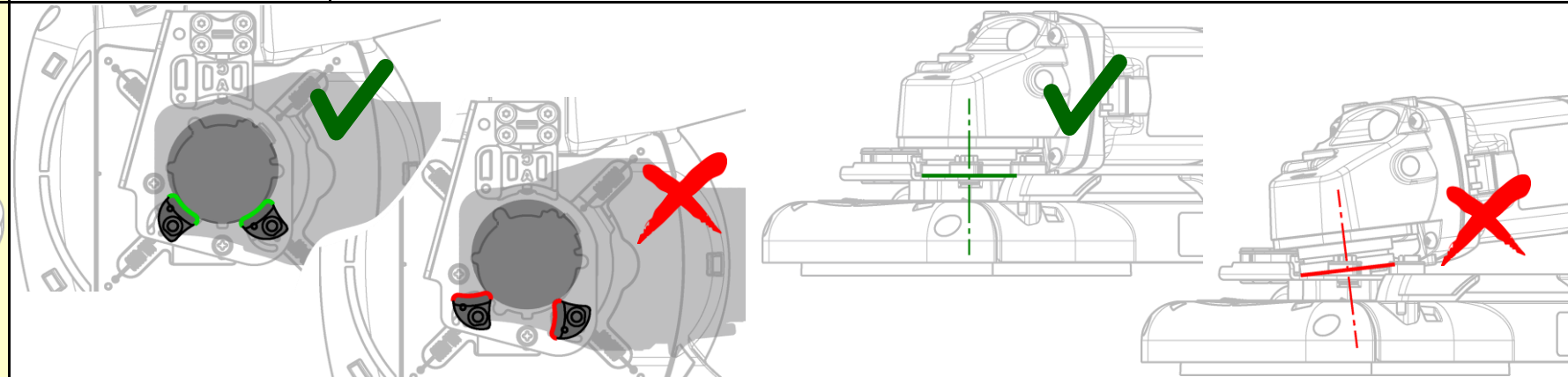

Place [a] on the gearcase of the Grinder.

Some models ONLY. [b]

2

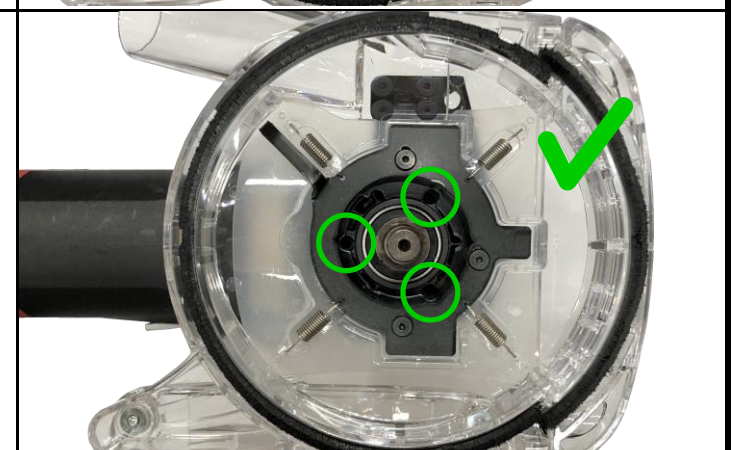
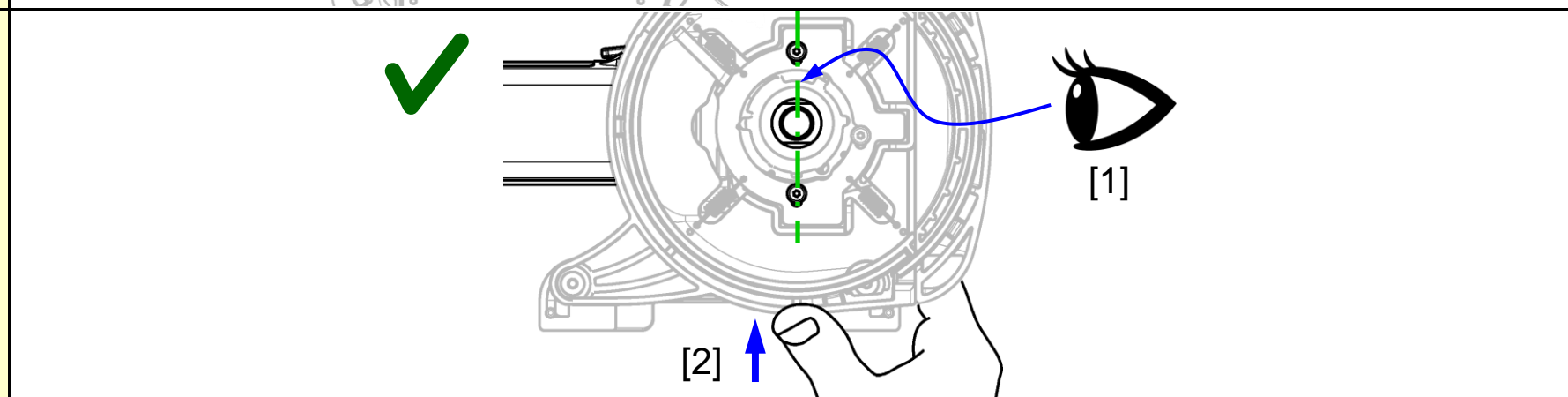

Set Upper / Lower Brackets at [a] Main Unit.

Upper Bracket [a]
Lower Brackets

1

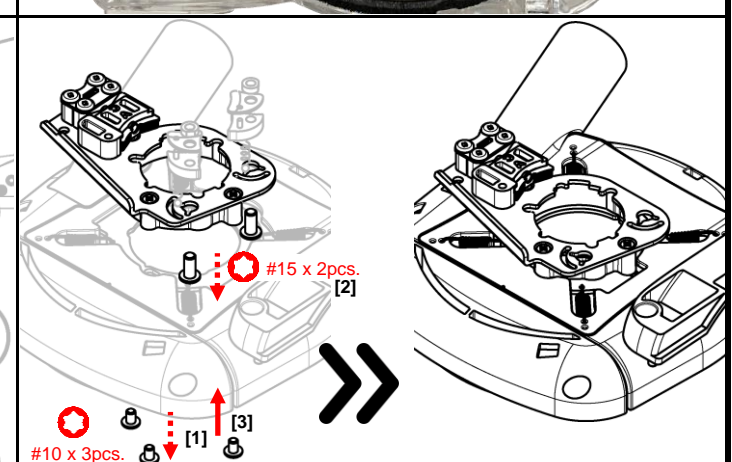
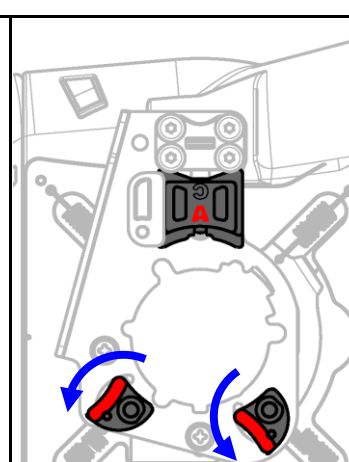
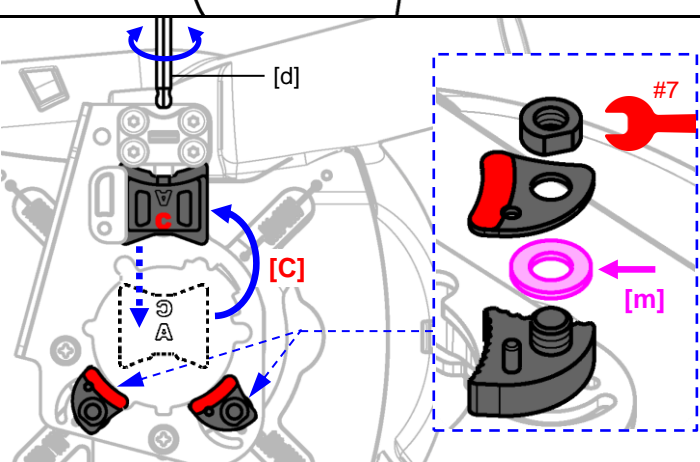
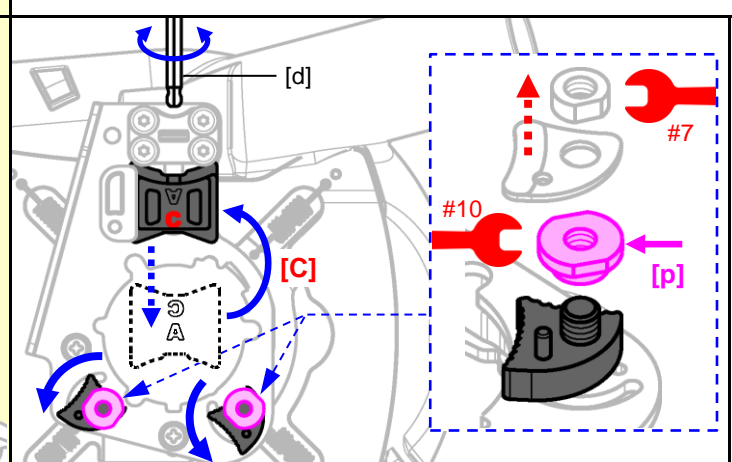

FLEX

※Based on the web information as of 2022 Jan.

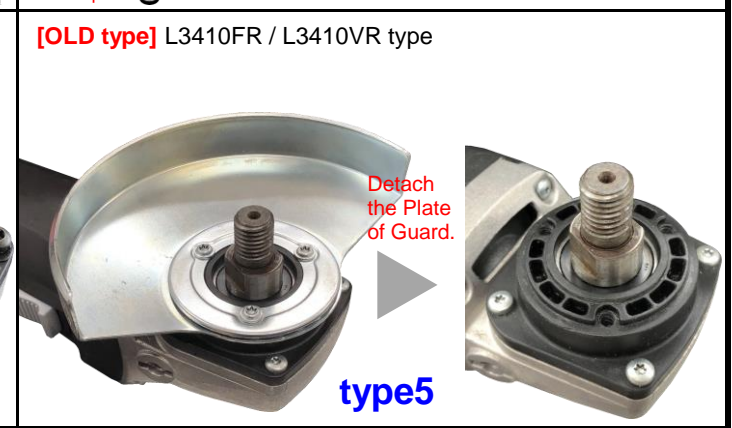
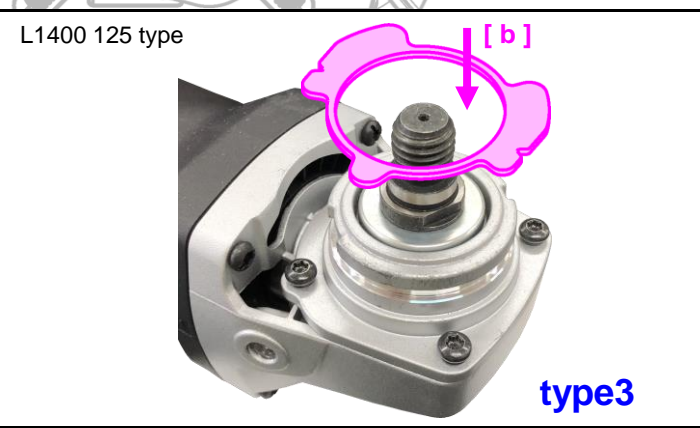



Check the
instruction
video.

