

Makita

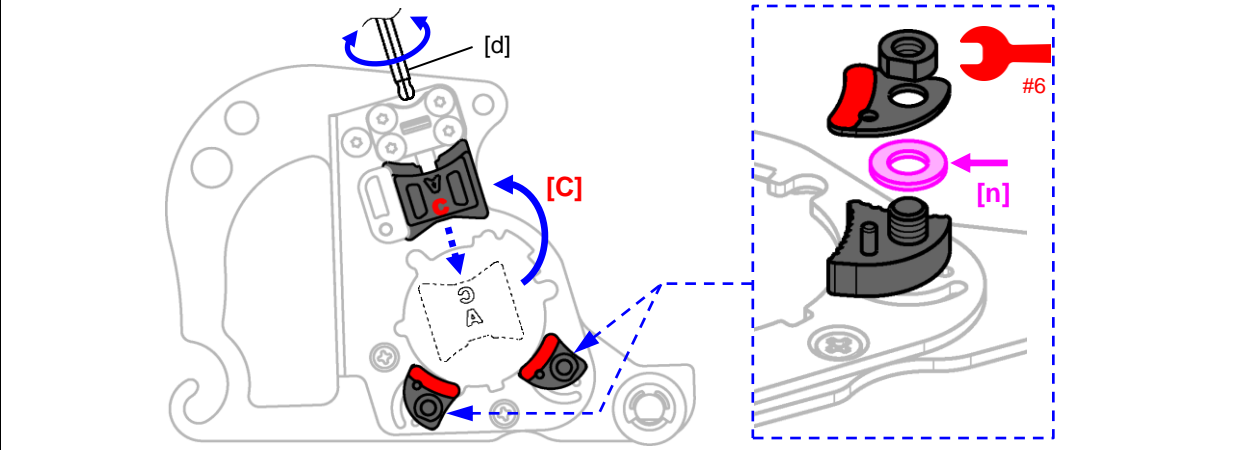

Original Flange

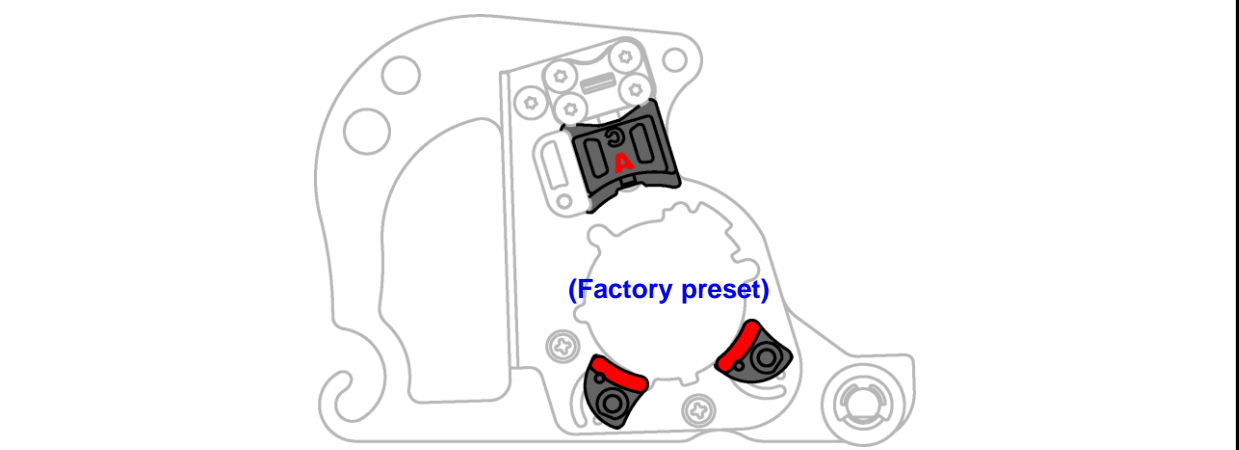
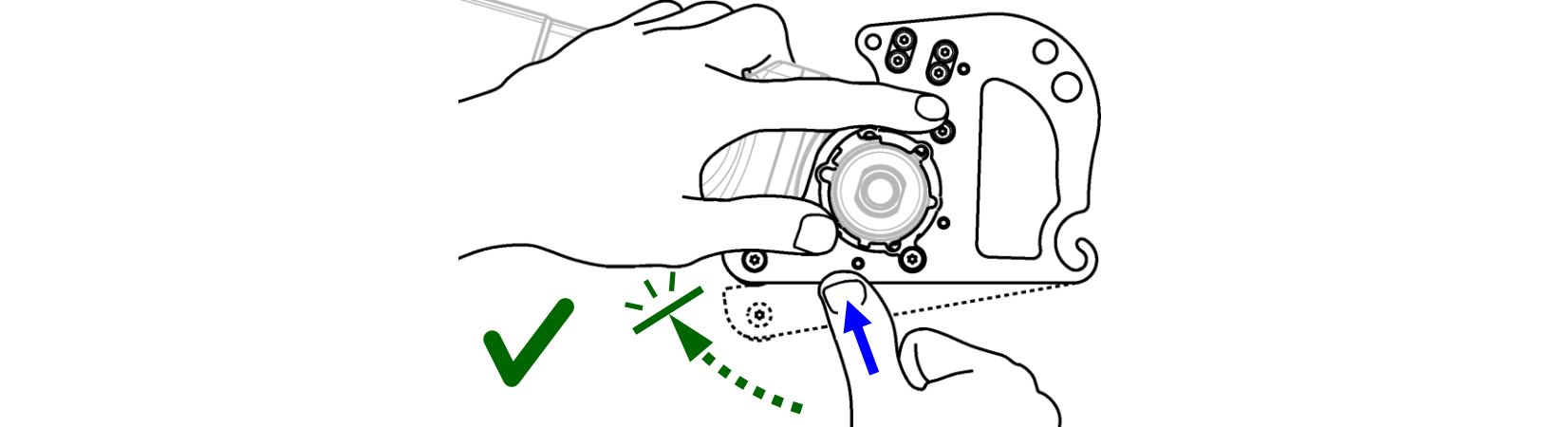
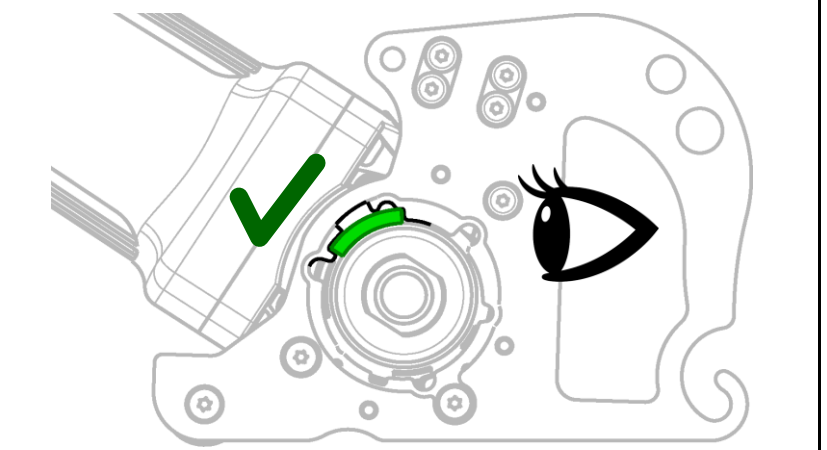
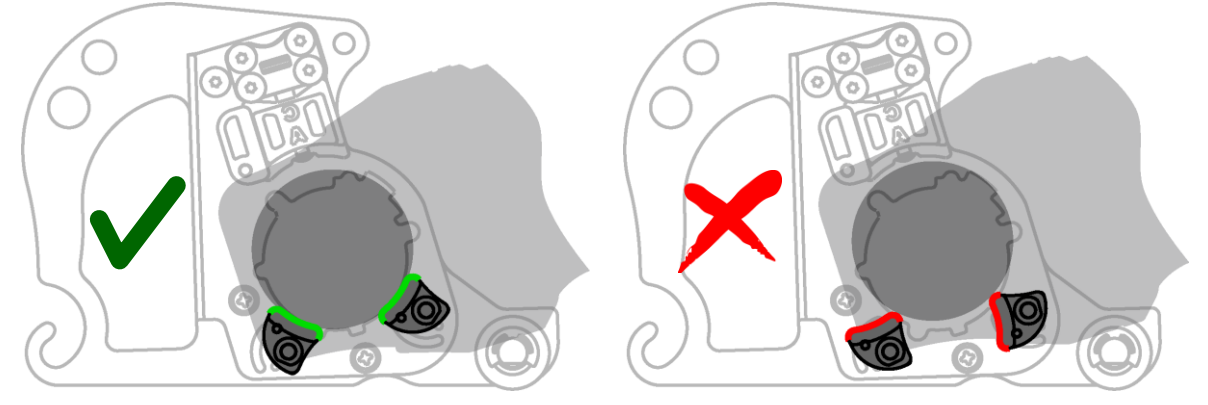
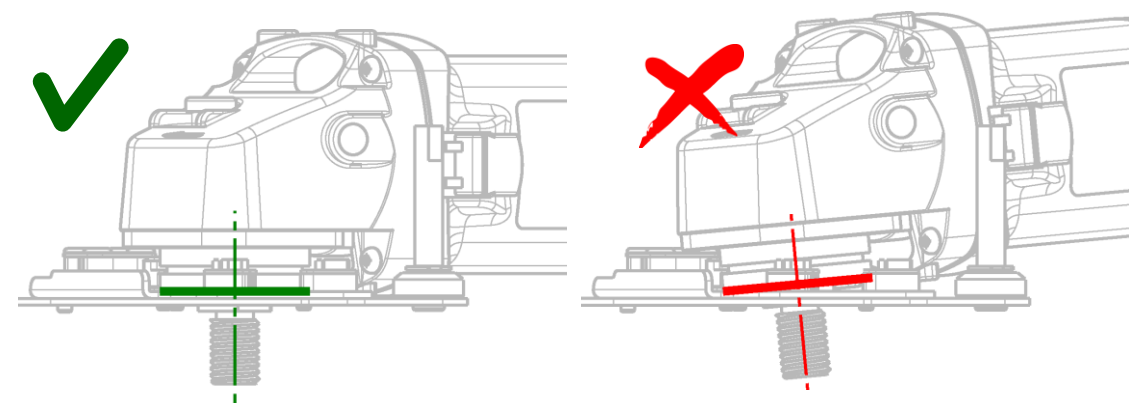
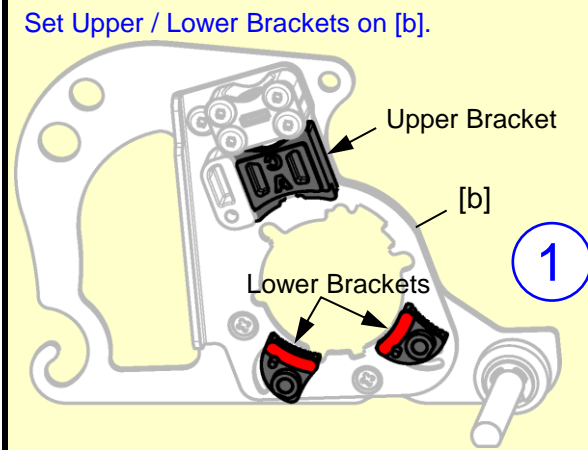
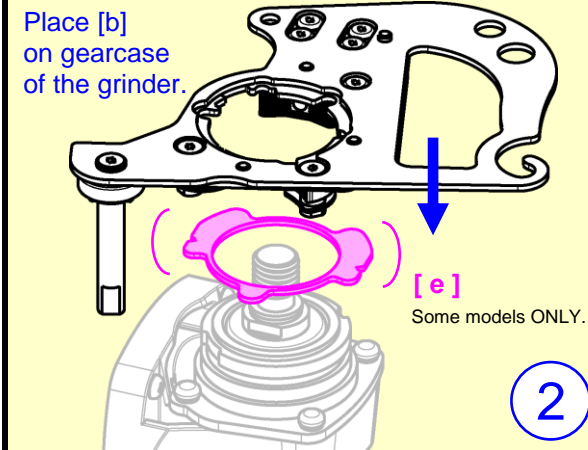
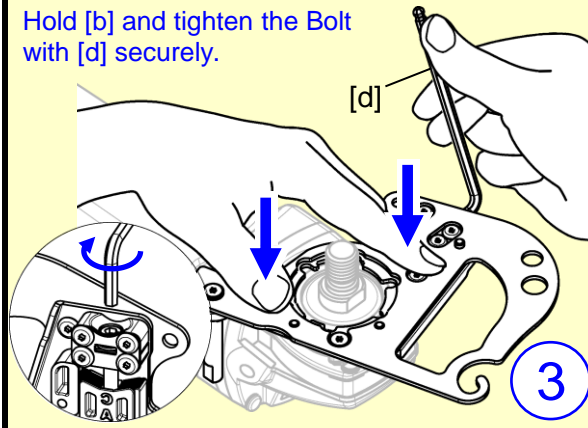
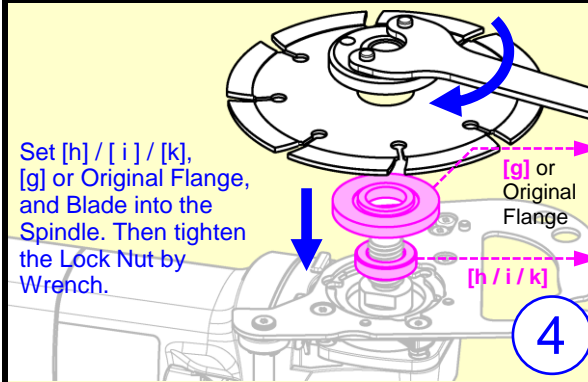

Makita

! XLOCK model can't be fitted.

※Based on the web information as of 2022 Jan.

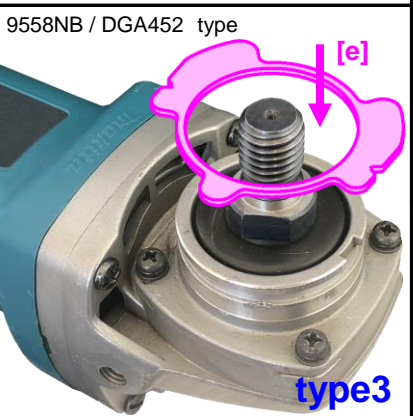
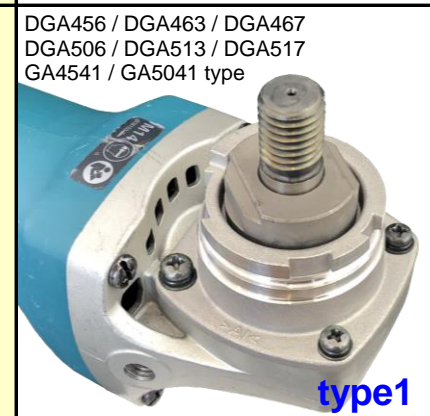
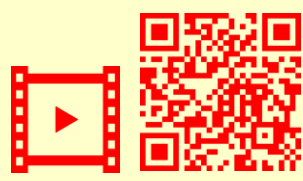

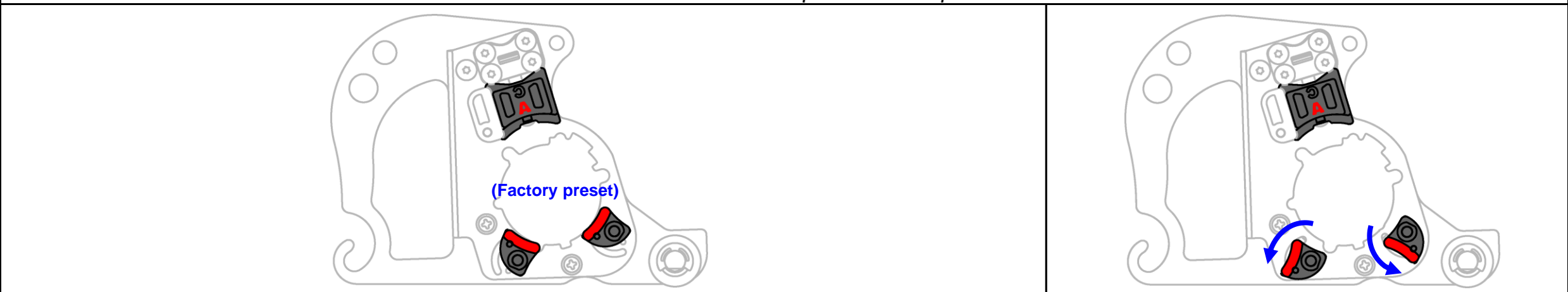
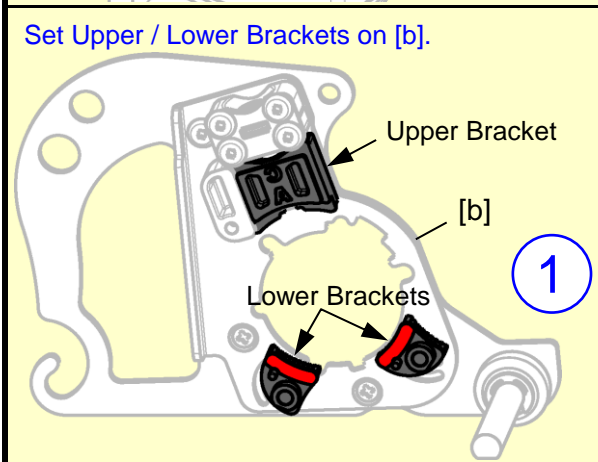
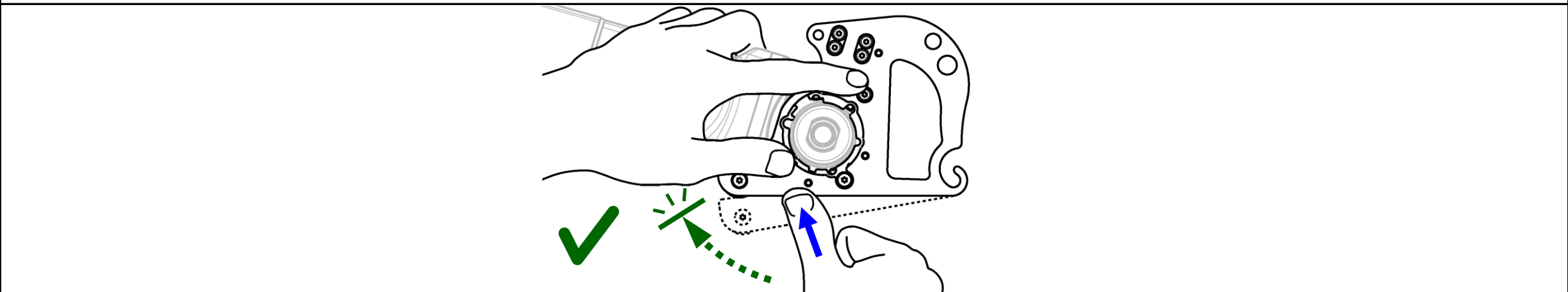
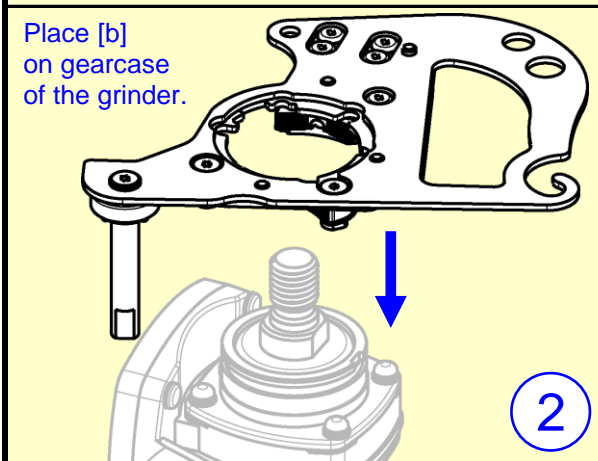
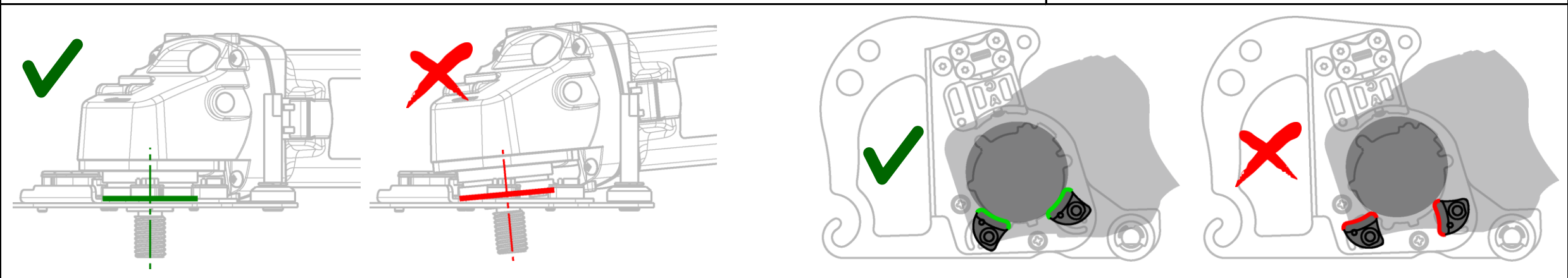
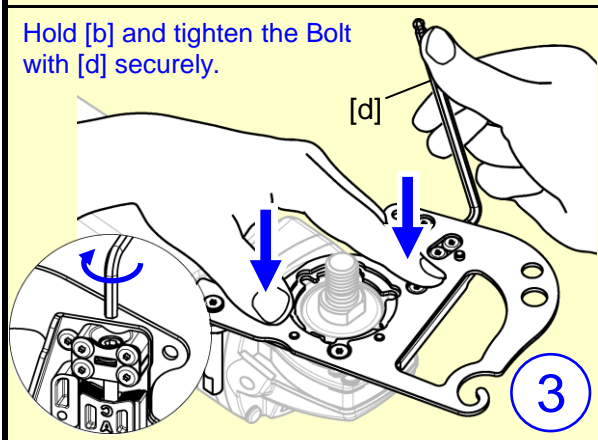
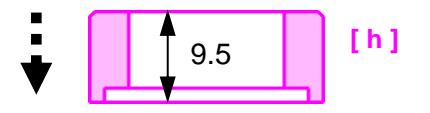
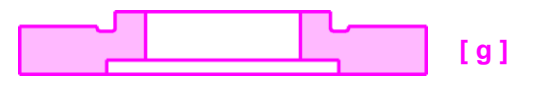
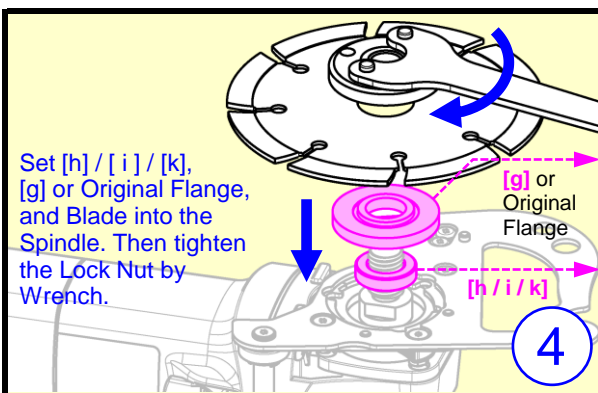

BOSCH

⚠ **XLOCK** model can't be fitted.

※Based on the web information as of 2022 Jan.

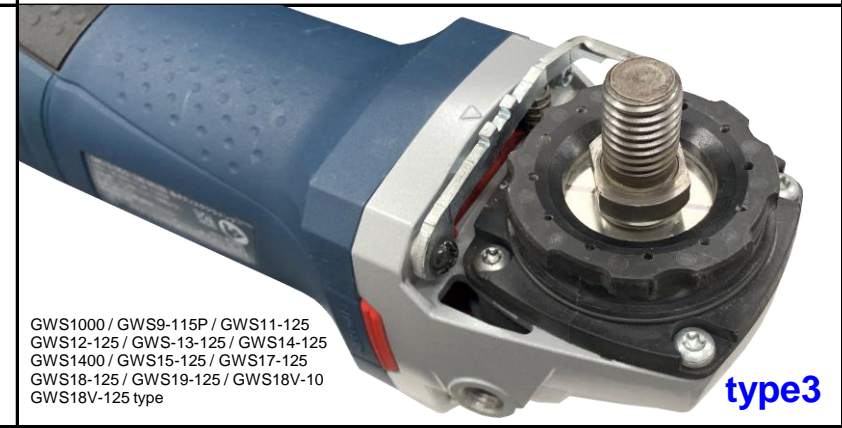
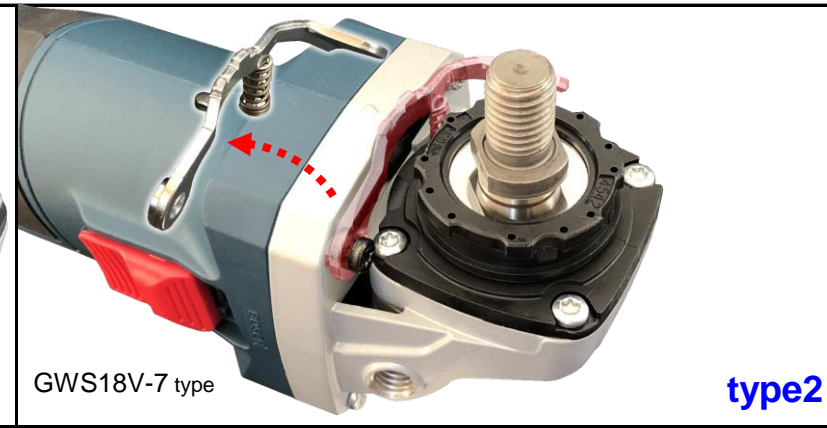

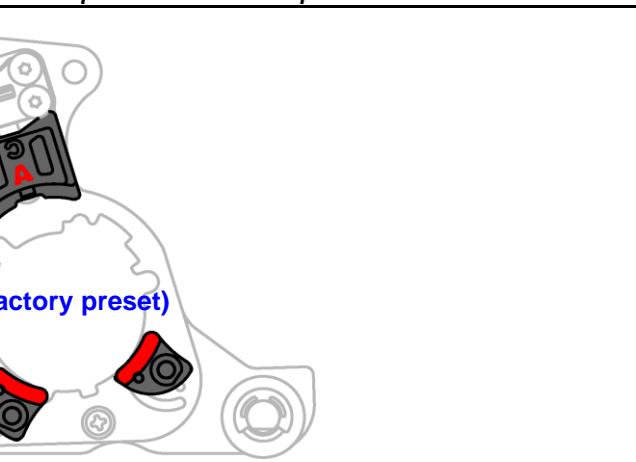
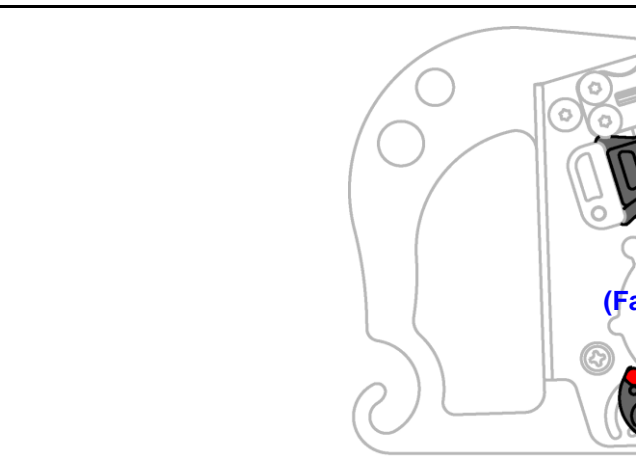
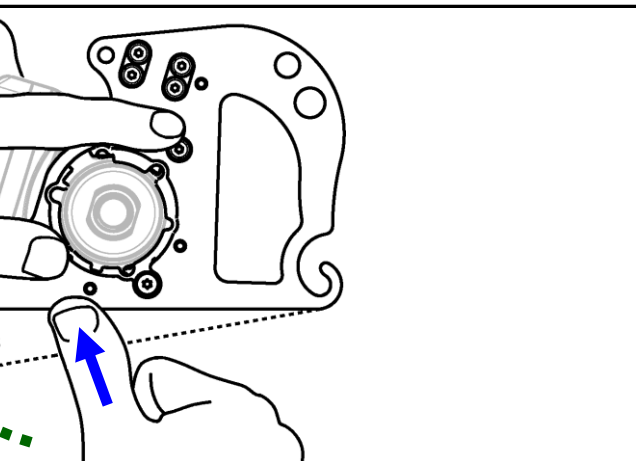
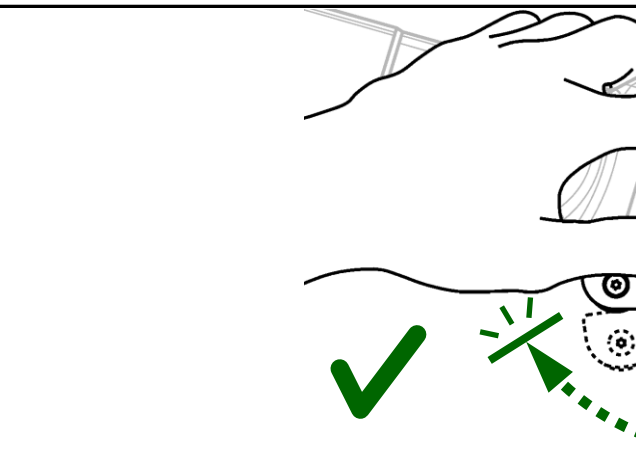
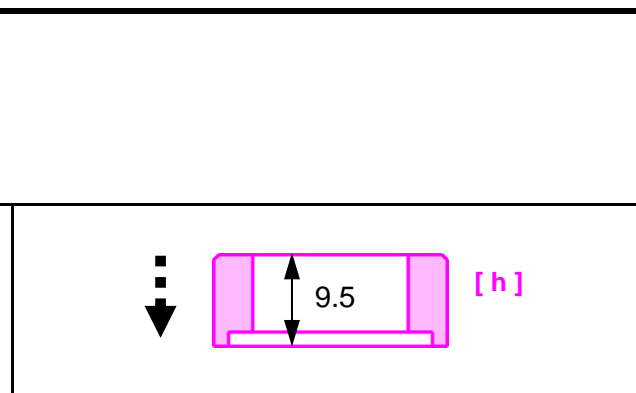
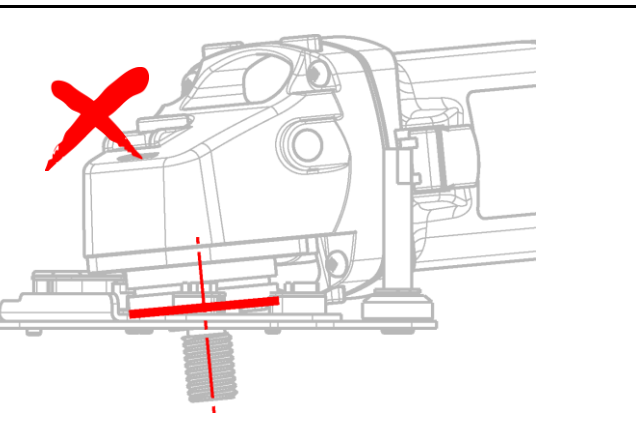
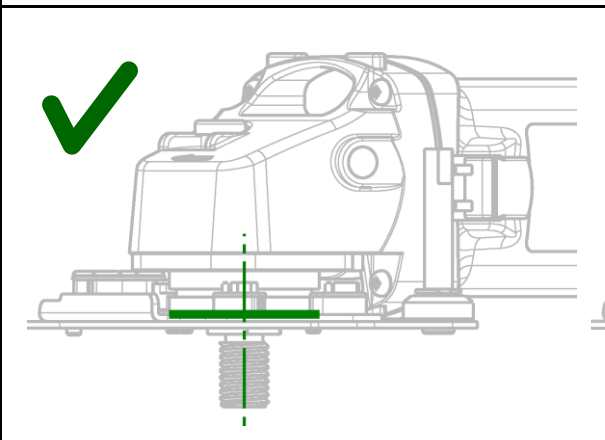
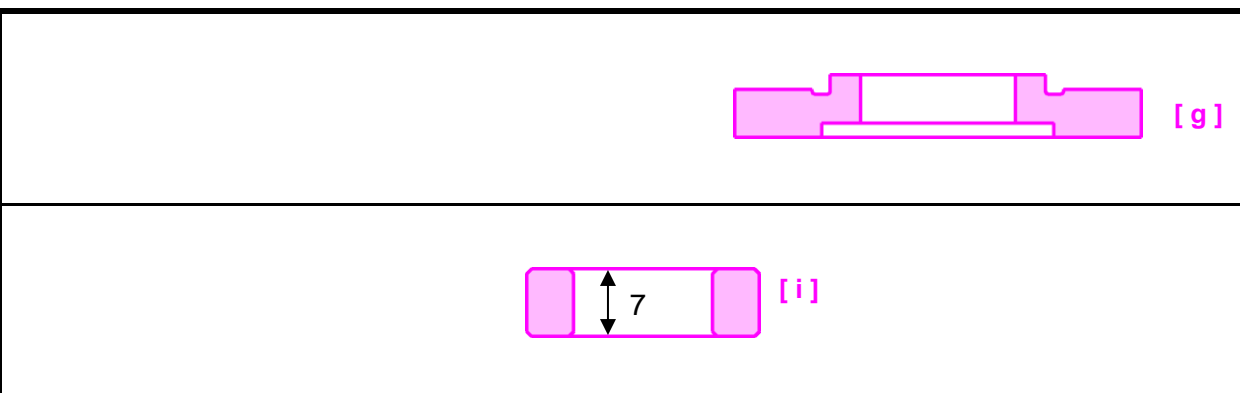
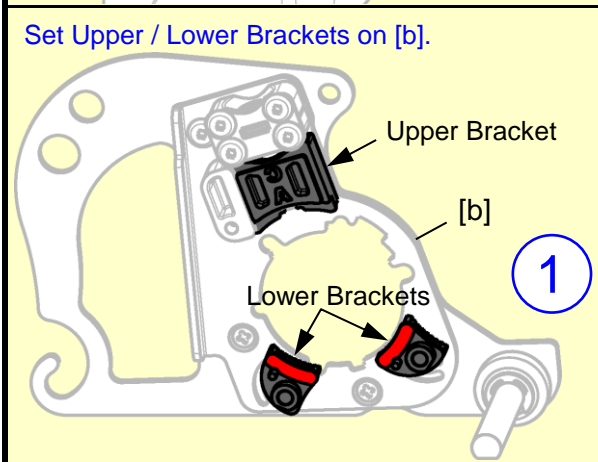
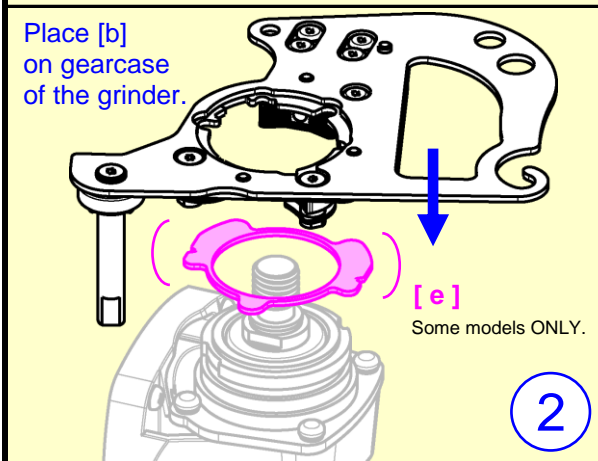
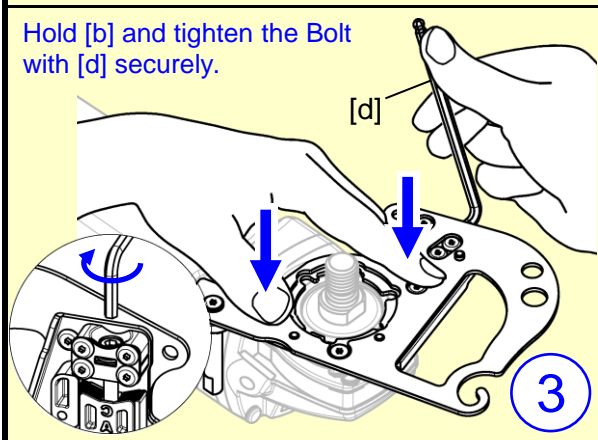
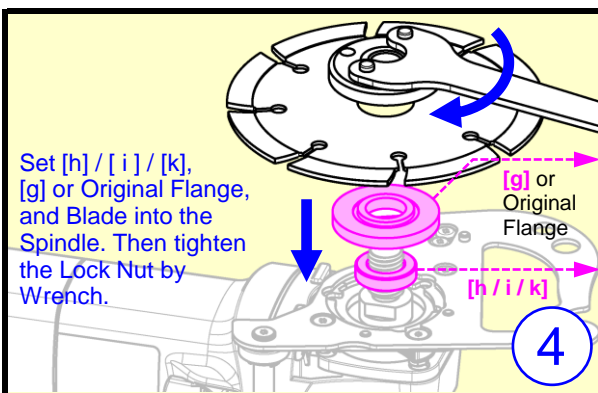

DEWALT

⚠ D28137 / DCG405FN can't be fitted.

※Based on the web information as of 2022 Jan.

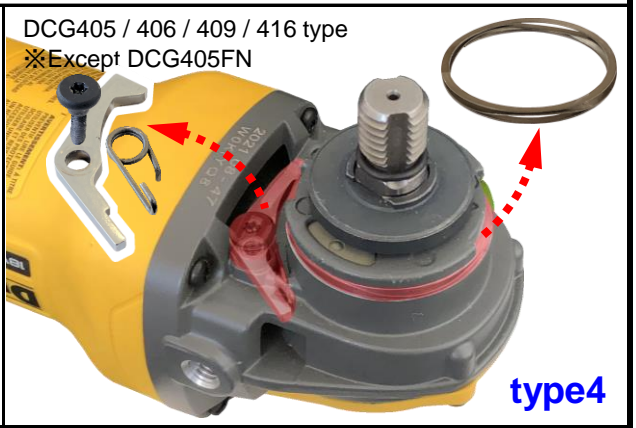
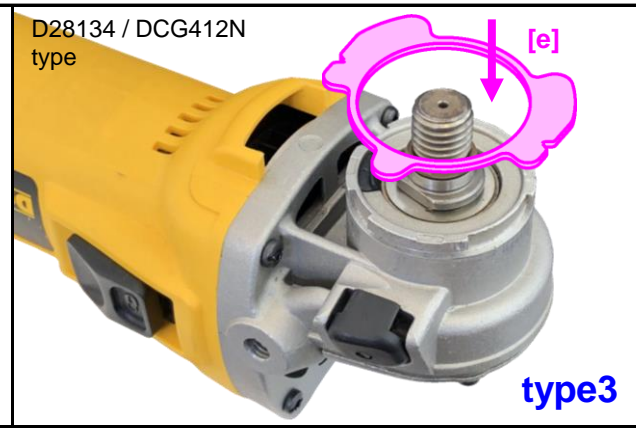
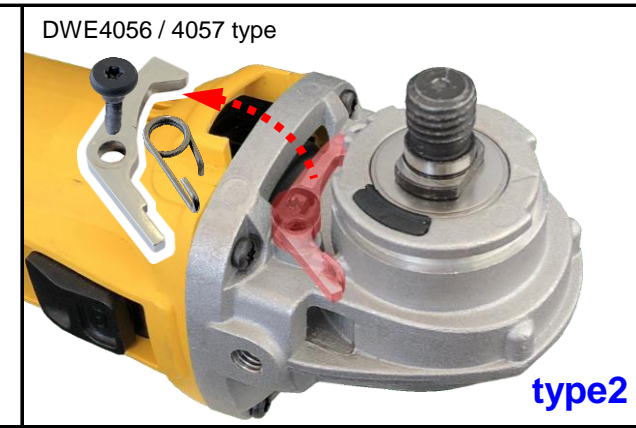
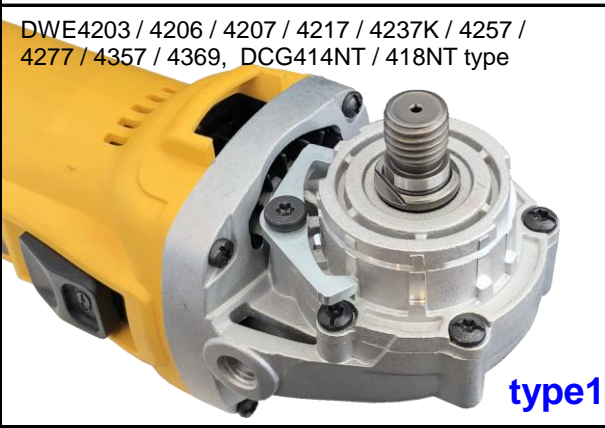

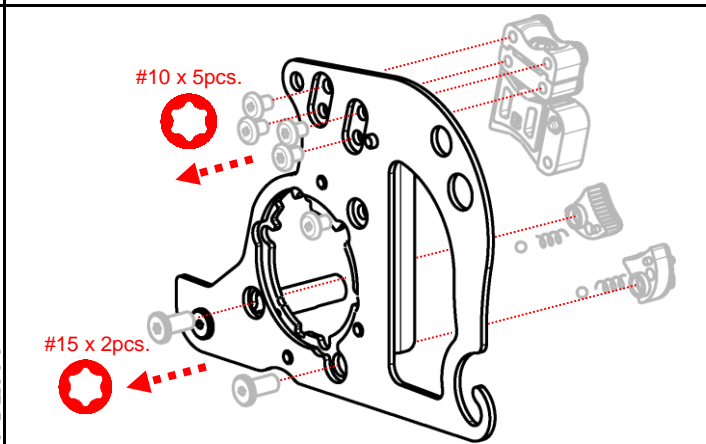
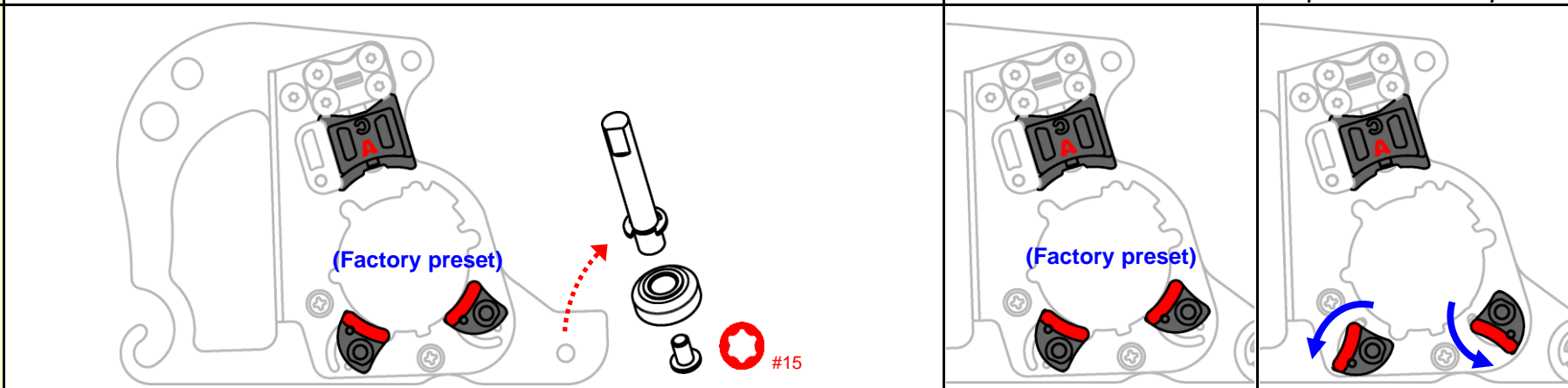
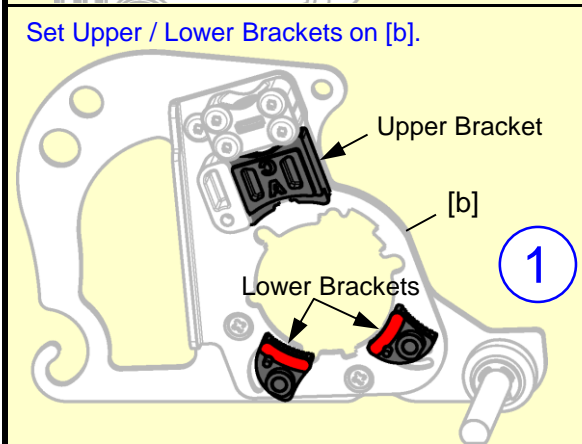
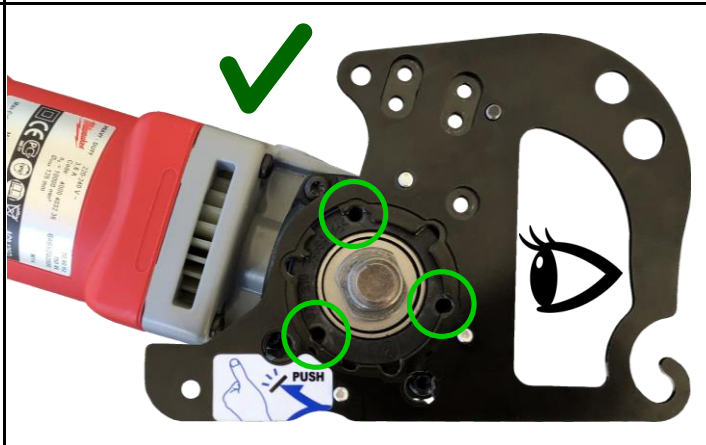
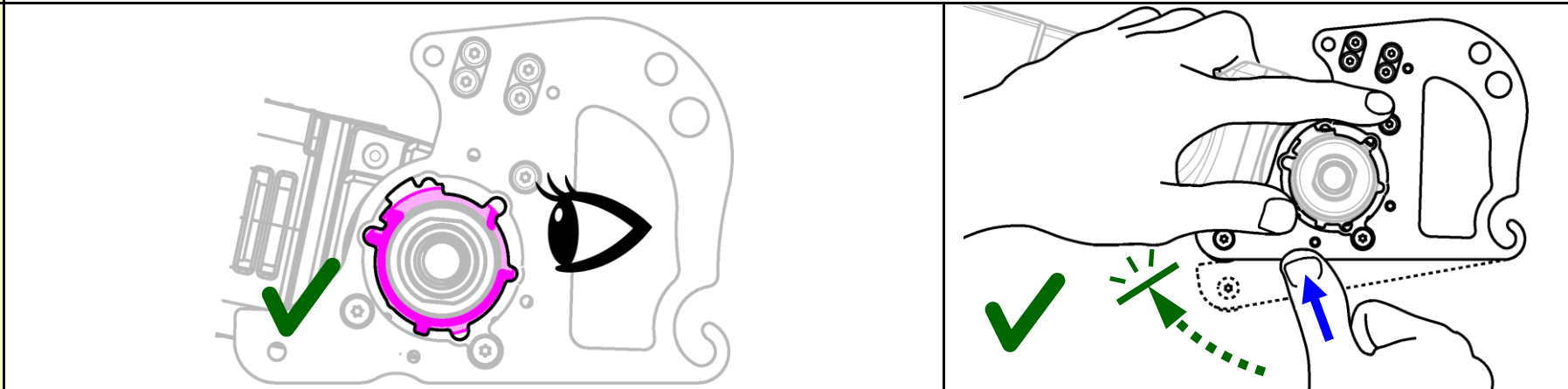
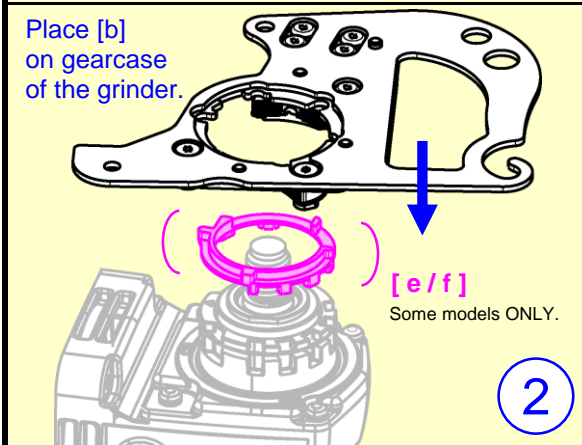
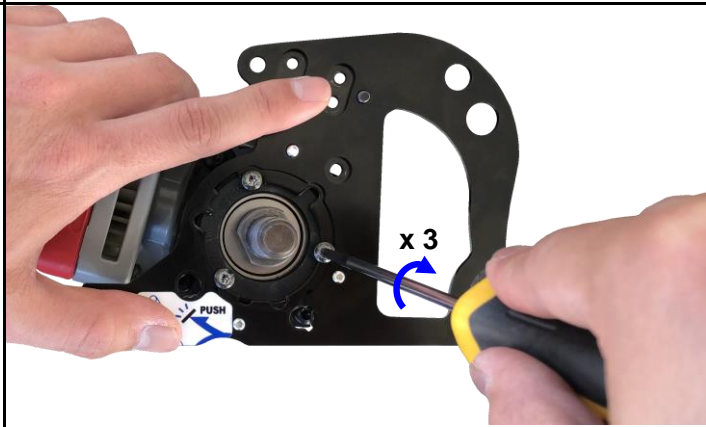
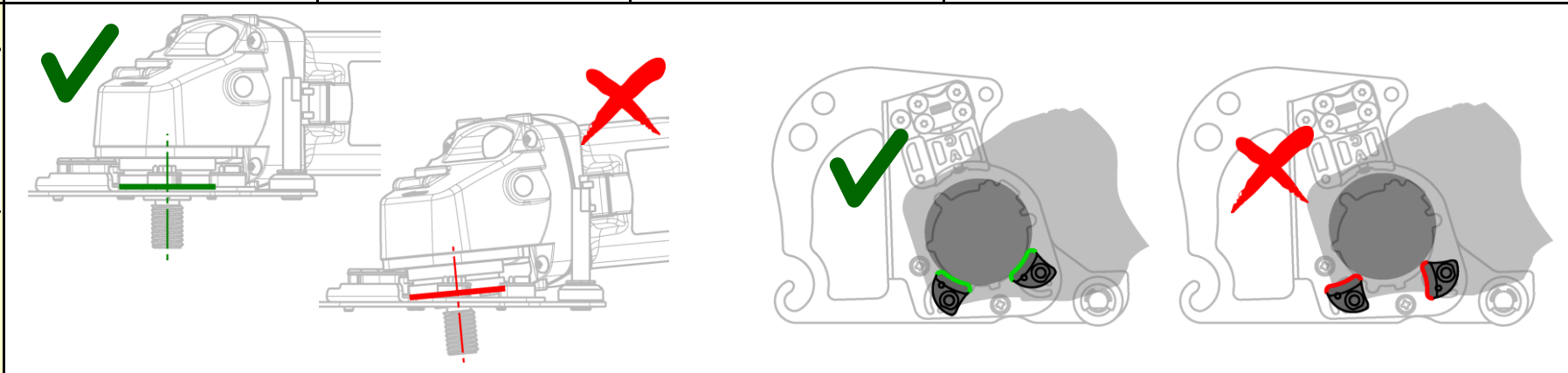
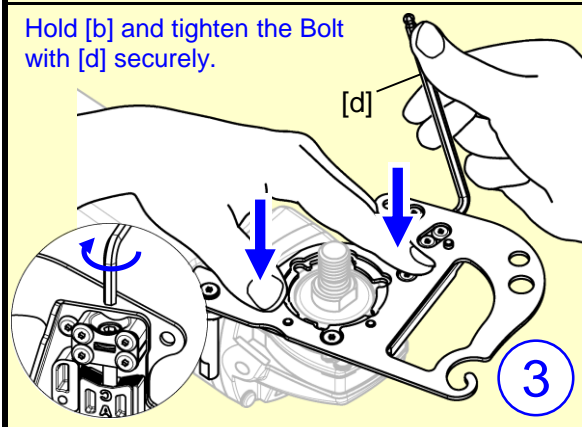
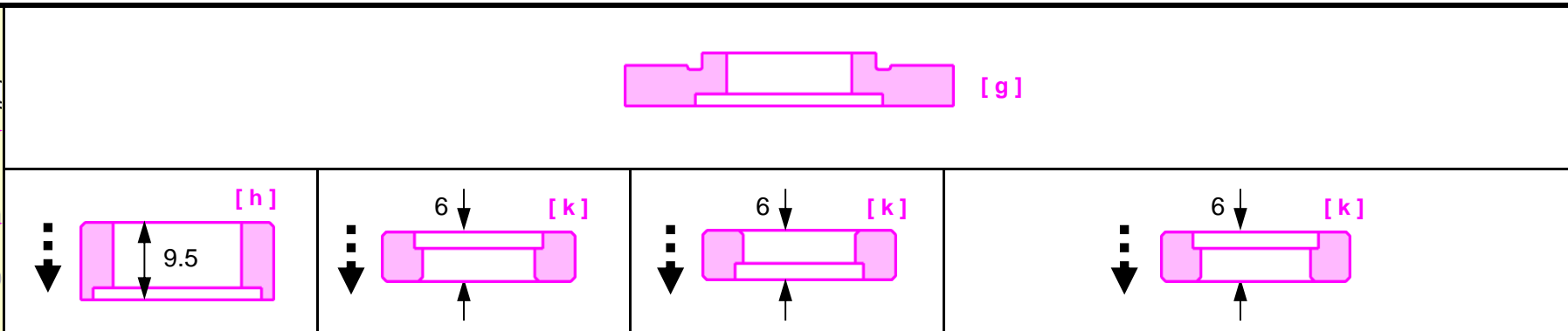
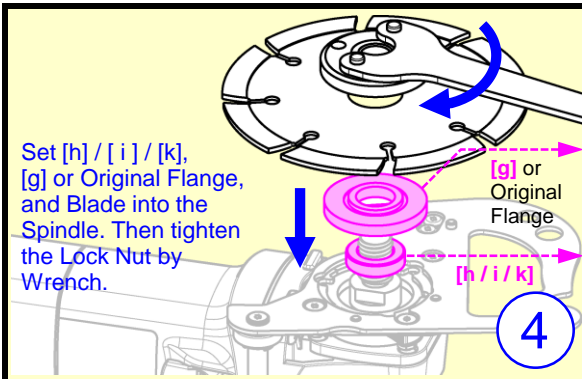

Milwaukee

⚠️ AGV10-125EK, AG10-125EK, AG800-125EK type can't be fitted.

※Based on the web information as of 2022 Jan.

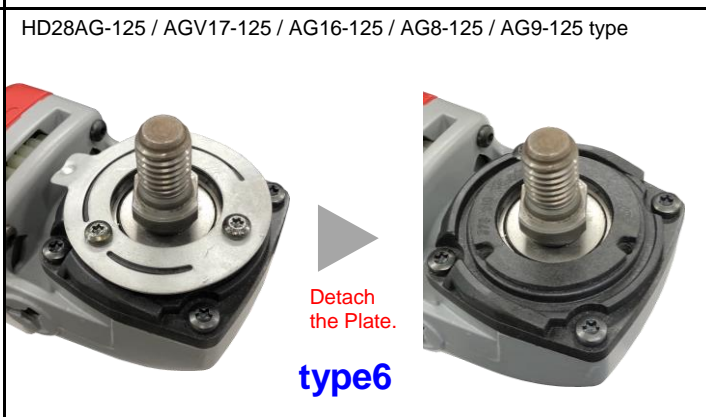
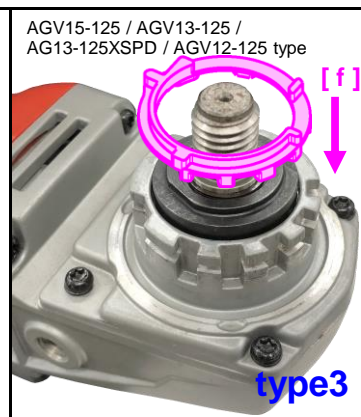
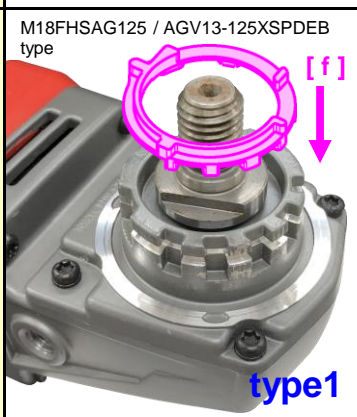



Set [h] / [i] / [k], [g] or Original Flange, and Blade into the Spindle. Then tighten the Lock Nut by Wrench.



Hold [b] and tighten the Bolt with [d] securely.

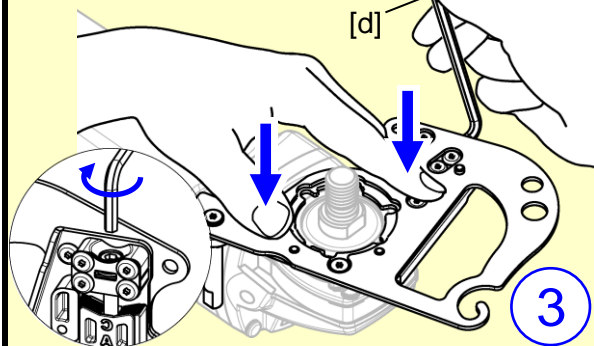

Place [b] on gearcase of the grinder.

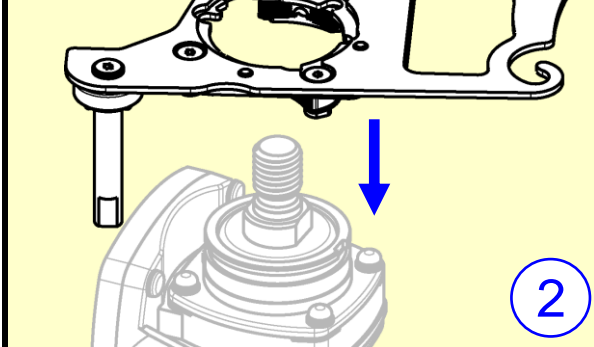

Set Upper / Lower Brackets on [b].

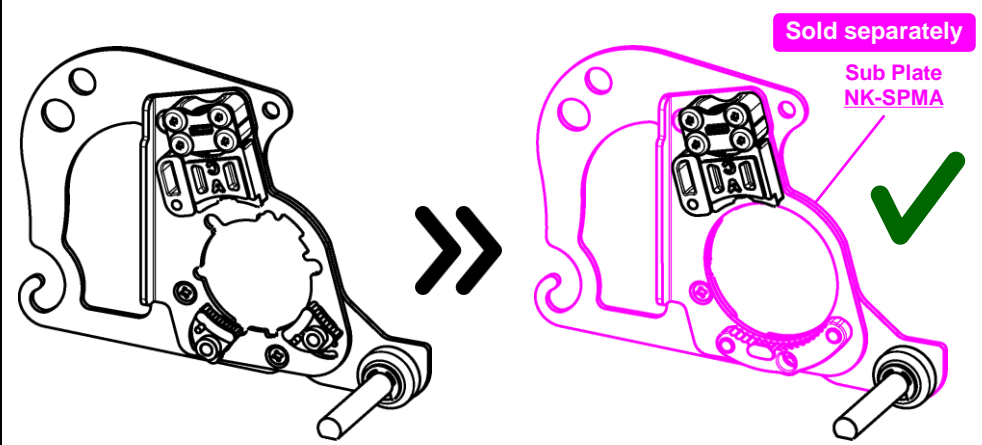
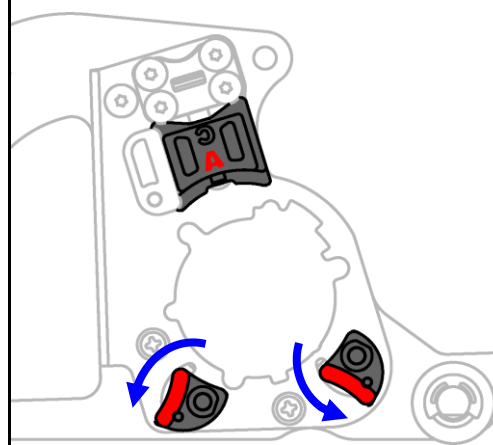
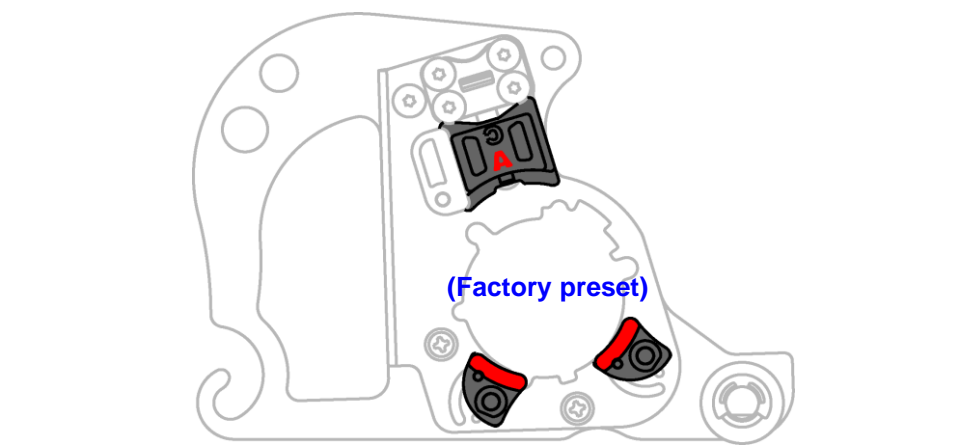
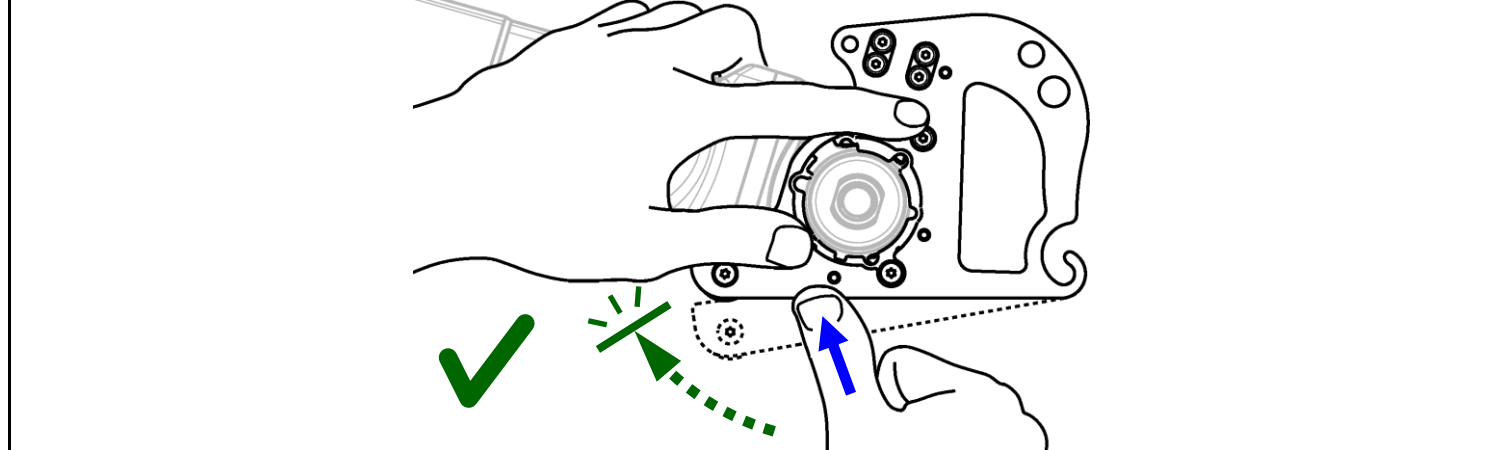
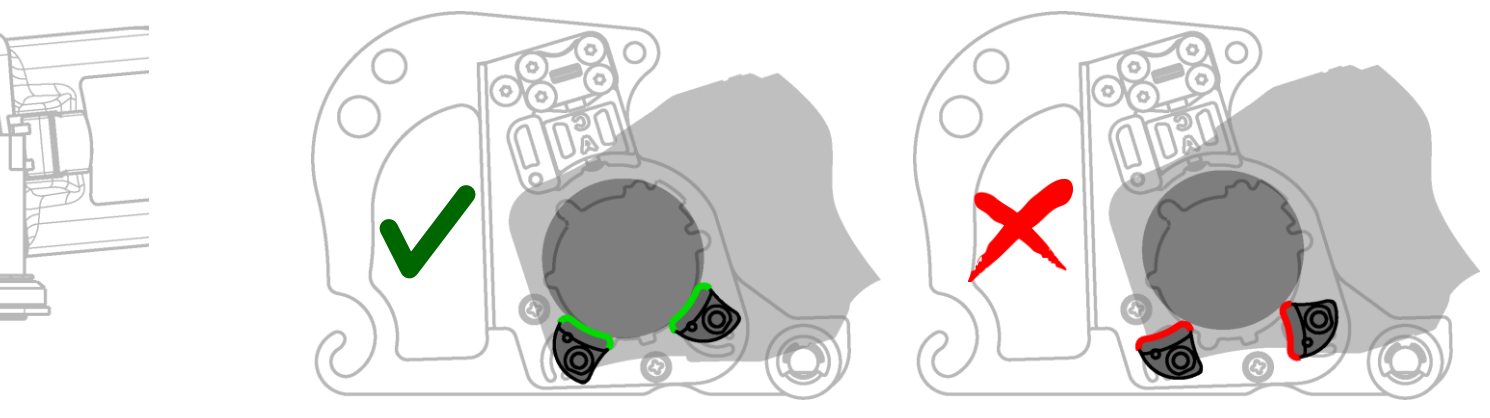
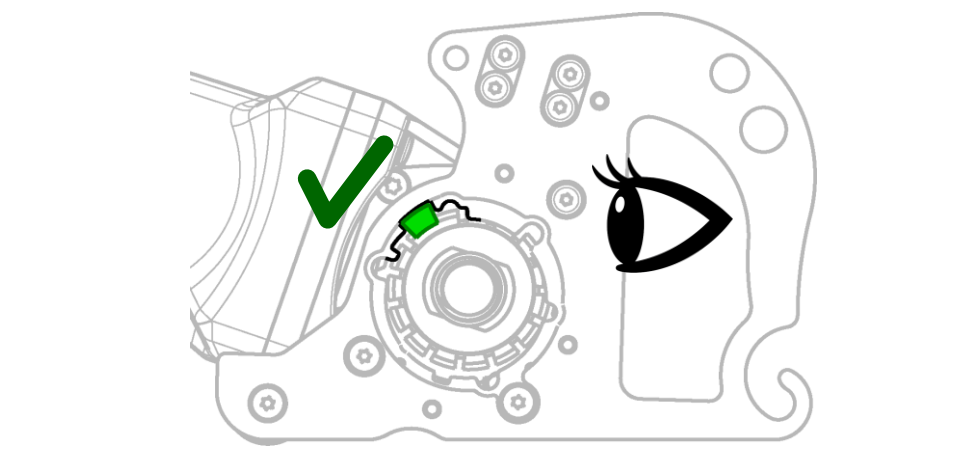
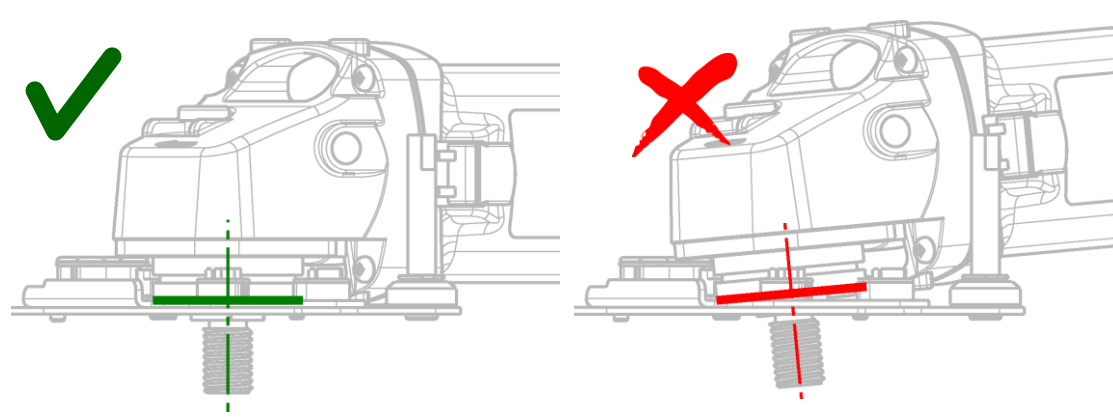
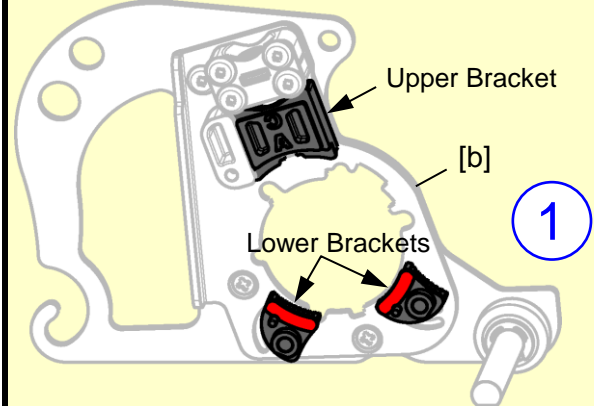

metabo

※Based on the web information as of 2022 Jan.

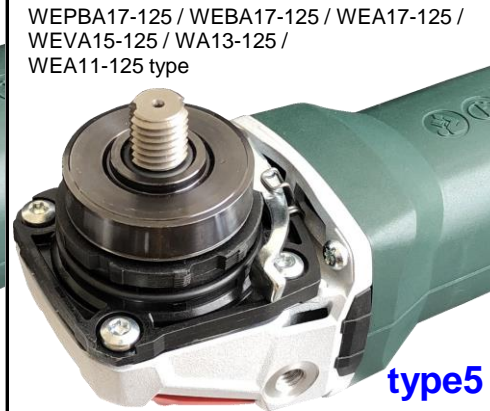
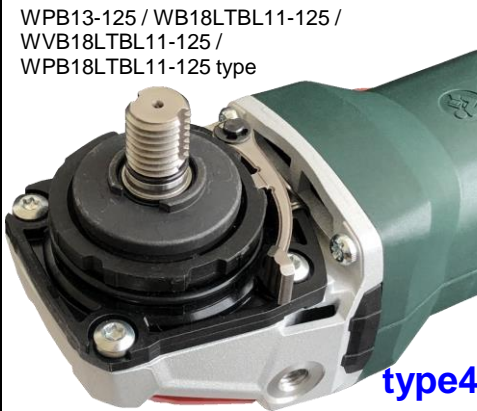
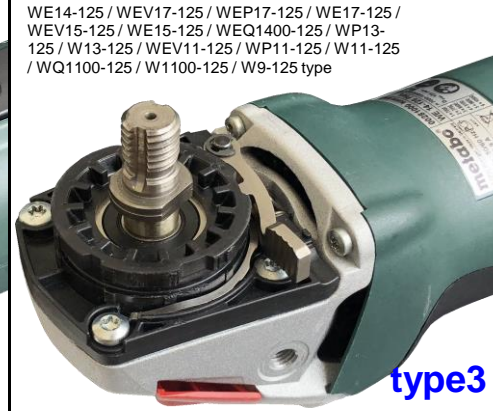
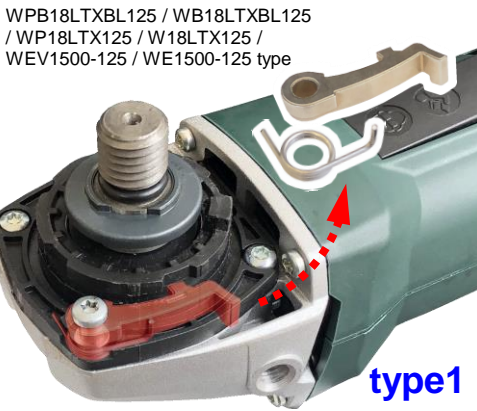

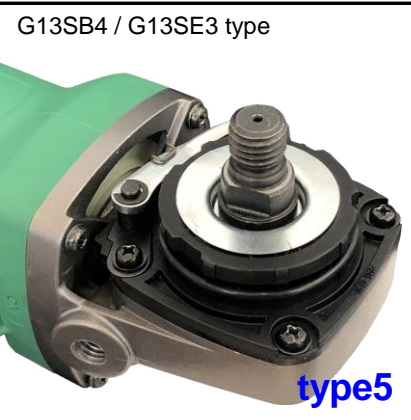
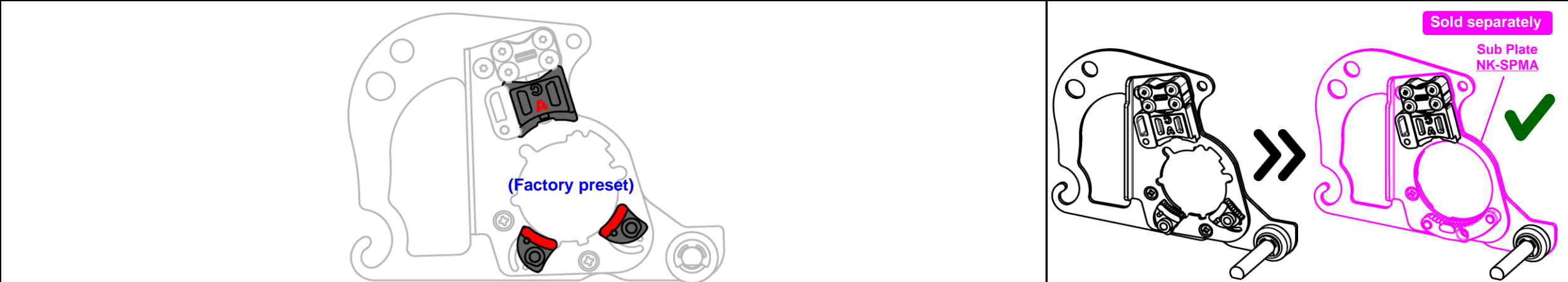
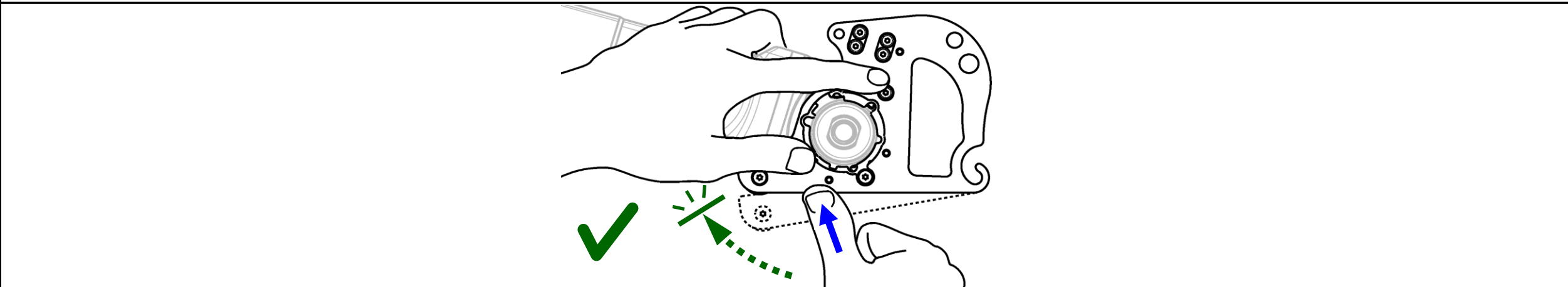
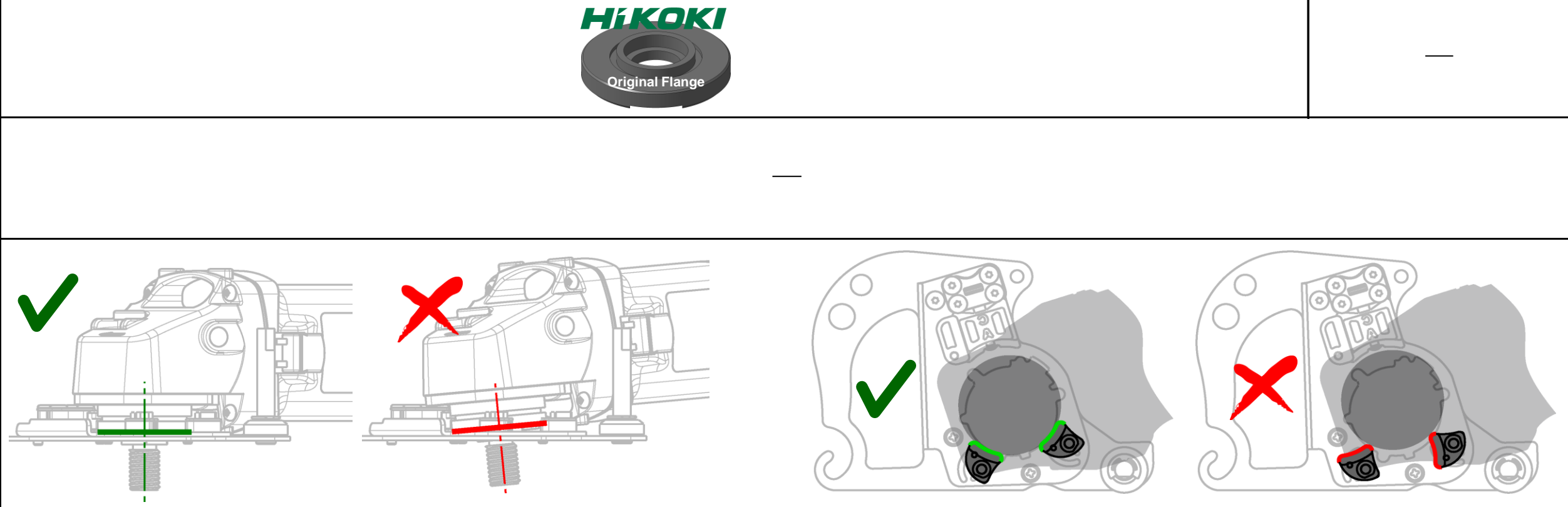
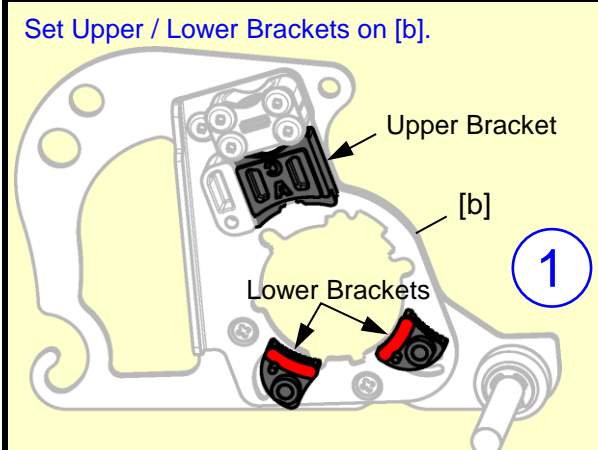
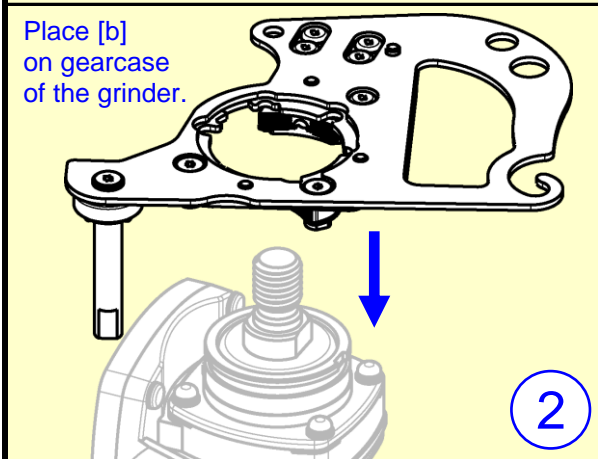
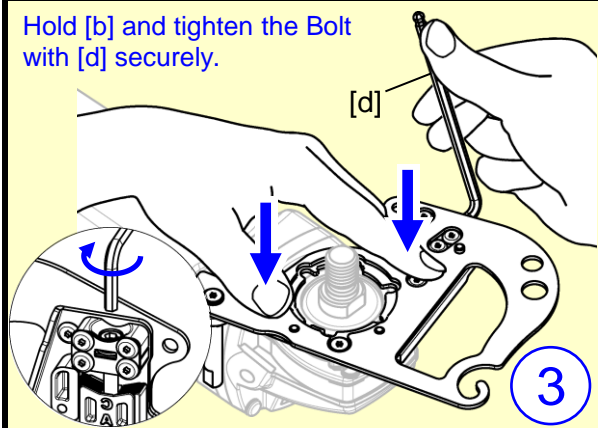
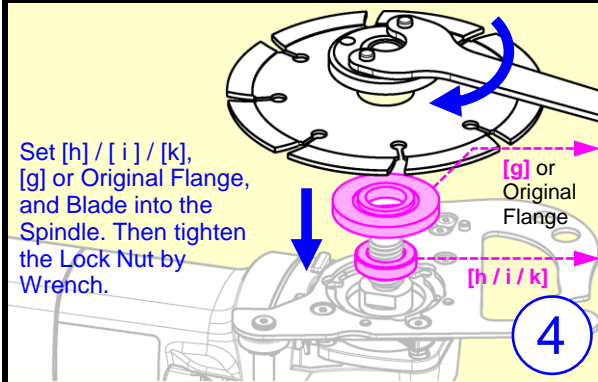

HIKOKI

※Based on the web information as of 2022 Jan.

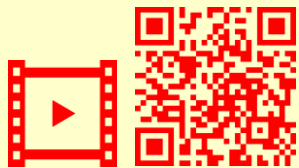

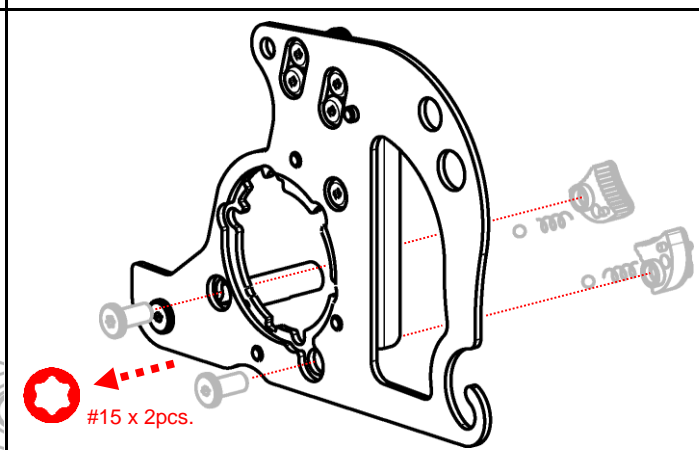
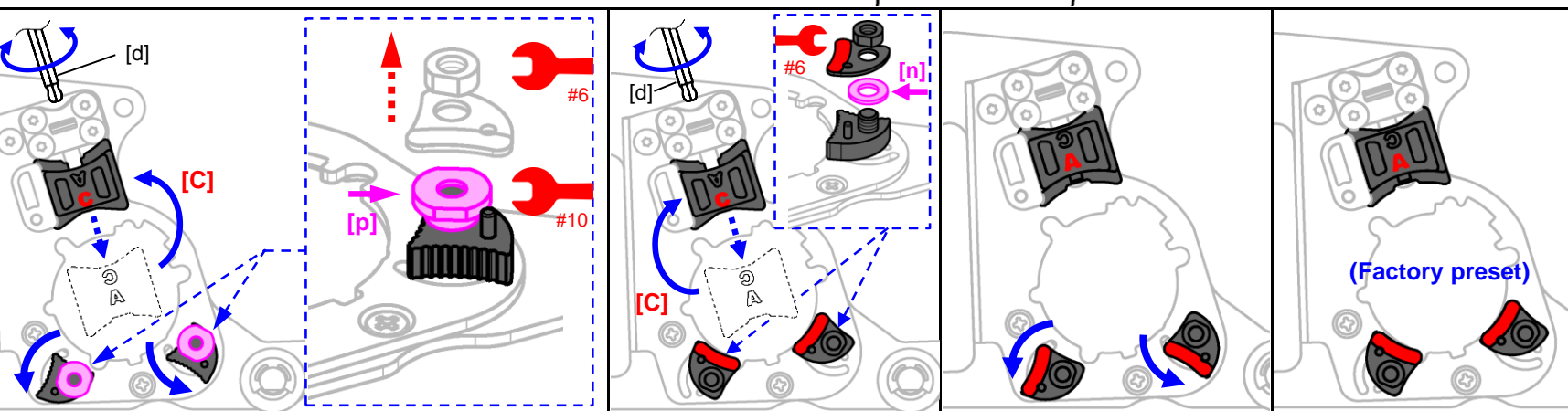
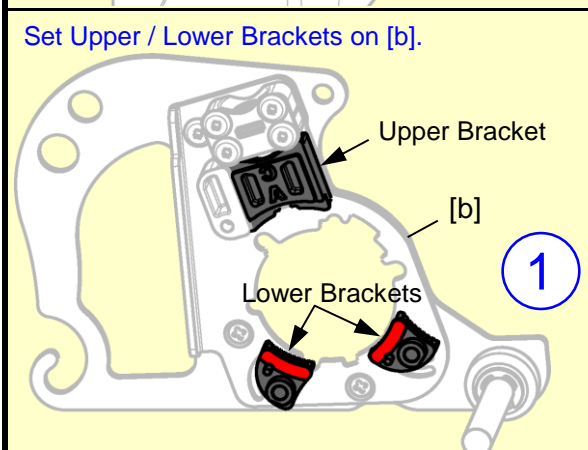
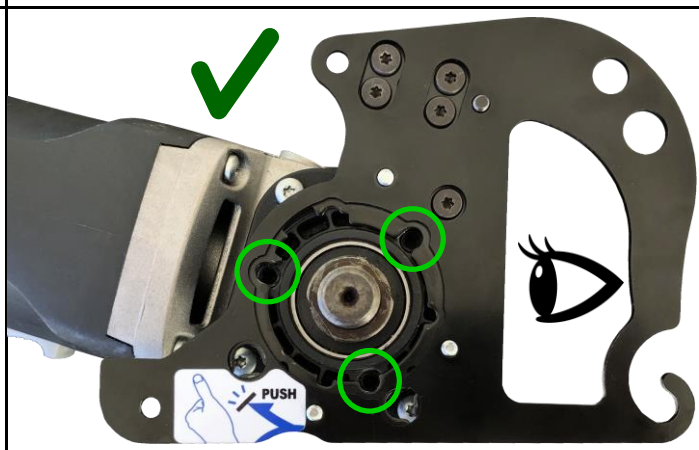
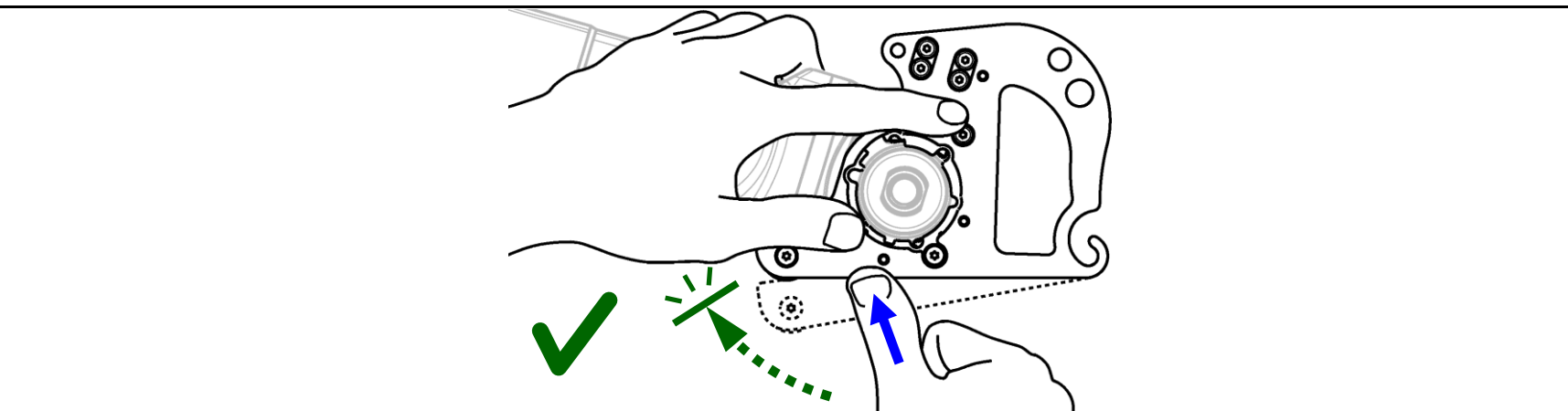
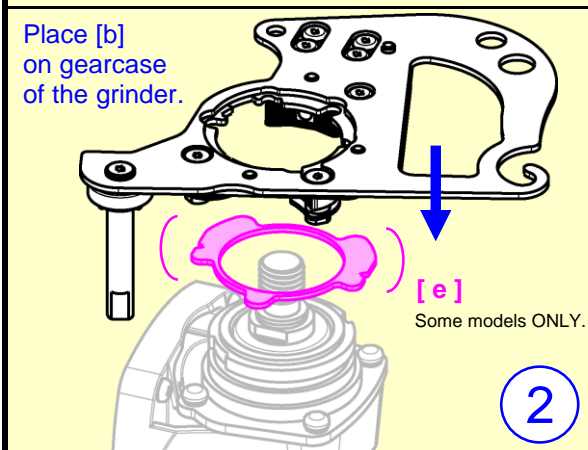
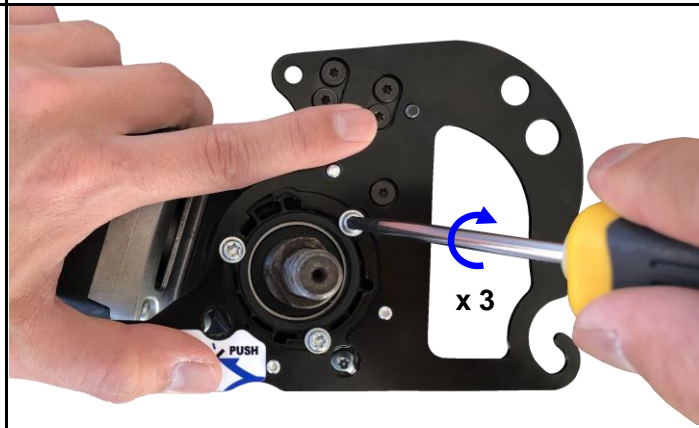
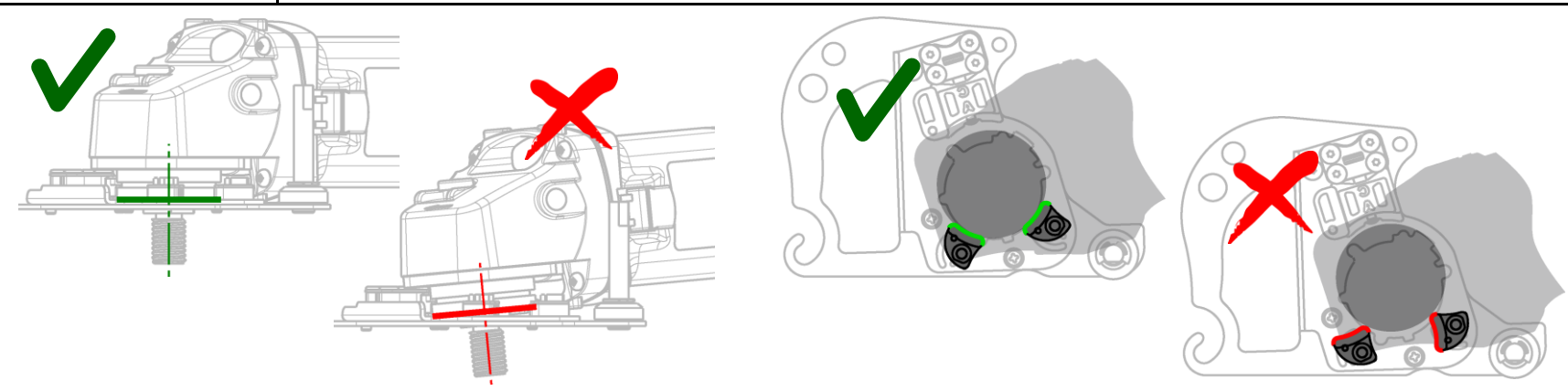
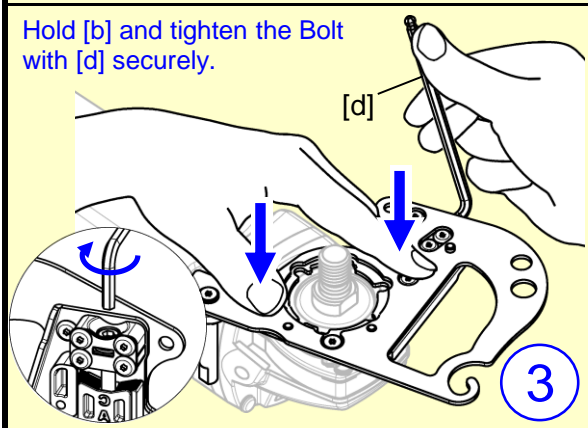
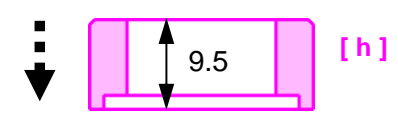
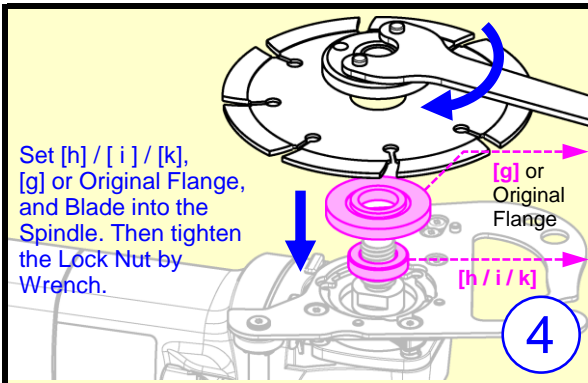

※Based on the web information as of 2022 Jan.

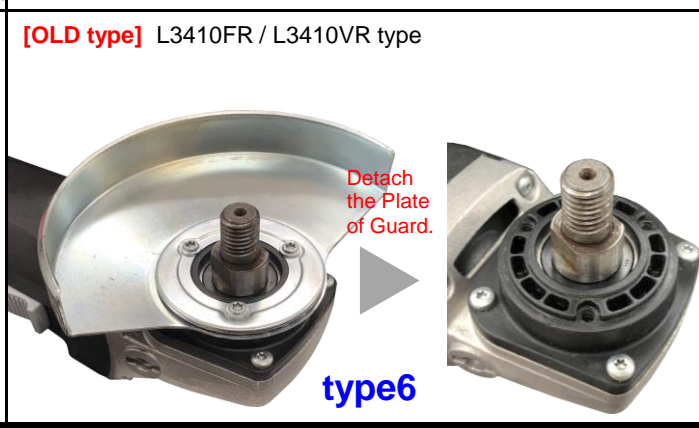



Check the
instruction
video.

